

ALMA MATER STUDIORUM - UNIVERSITA' DI BOLOGNA
CAMPUS DI CESENA
SCUOLA DI INGEGNERIA E ARCHITETTURA

CORSO DI LAUREA SPECIALISTICA/MAGISTRALE A CICLO UNICO IN
ARCHITETTURA

TITOLO DELLA TESI

Verso l'altro lato.
La Villa 31 di Buenos Aires

Tesi in
Architettura e composizione architettonica III

Relatore
Antonio Esposito

Presentata da
Daniela Mastronardi

Correlatori
Martina D'Alessandro
Carlos Campos

Anno Accademico 2019/2020





0 1000 2000 5000

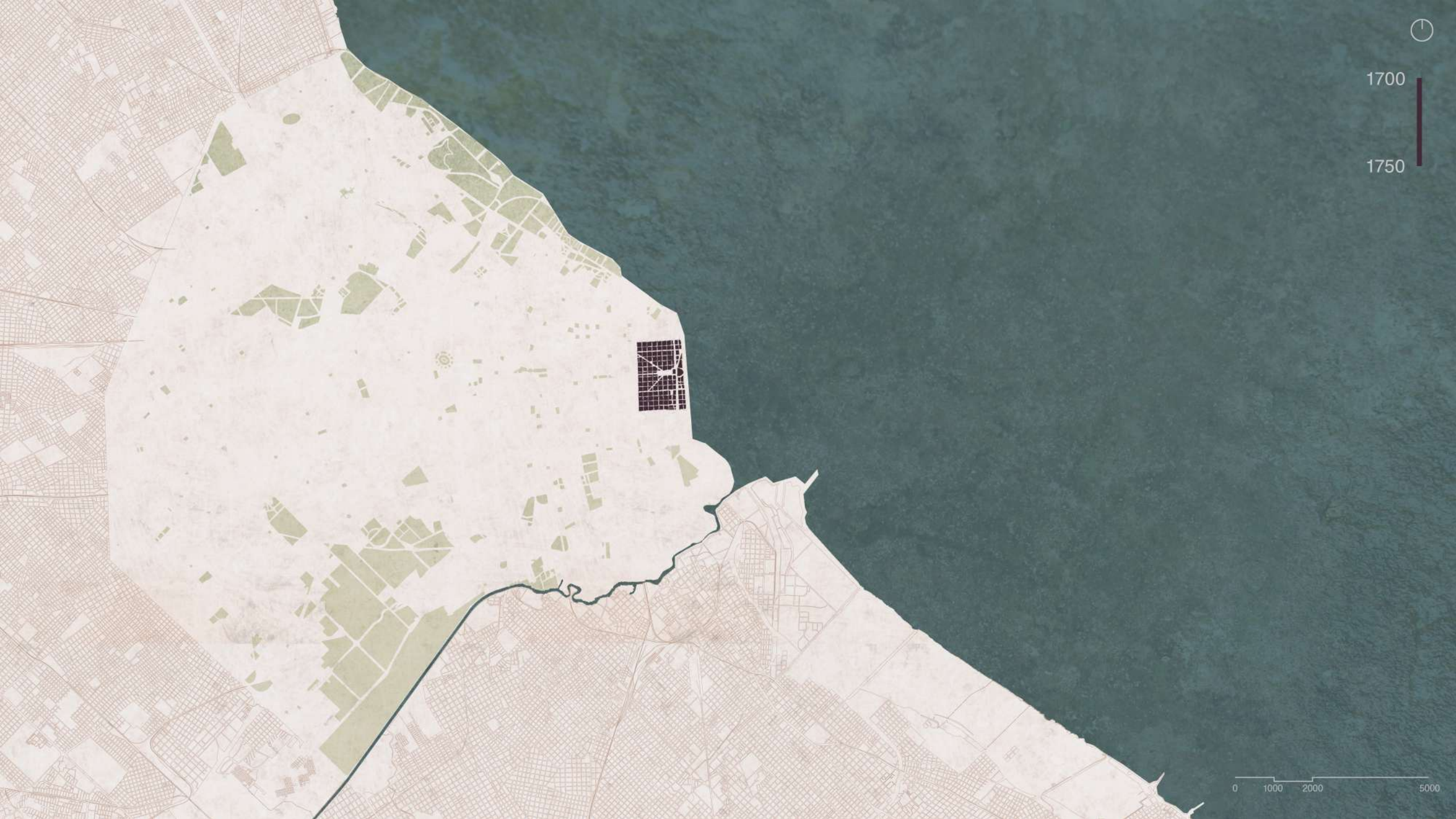

1700

1750

0 1000 2000 5000



1700

1750

1800

0 1000 2000 5000

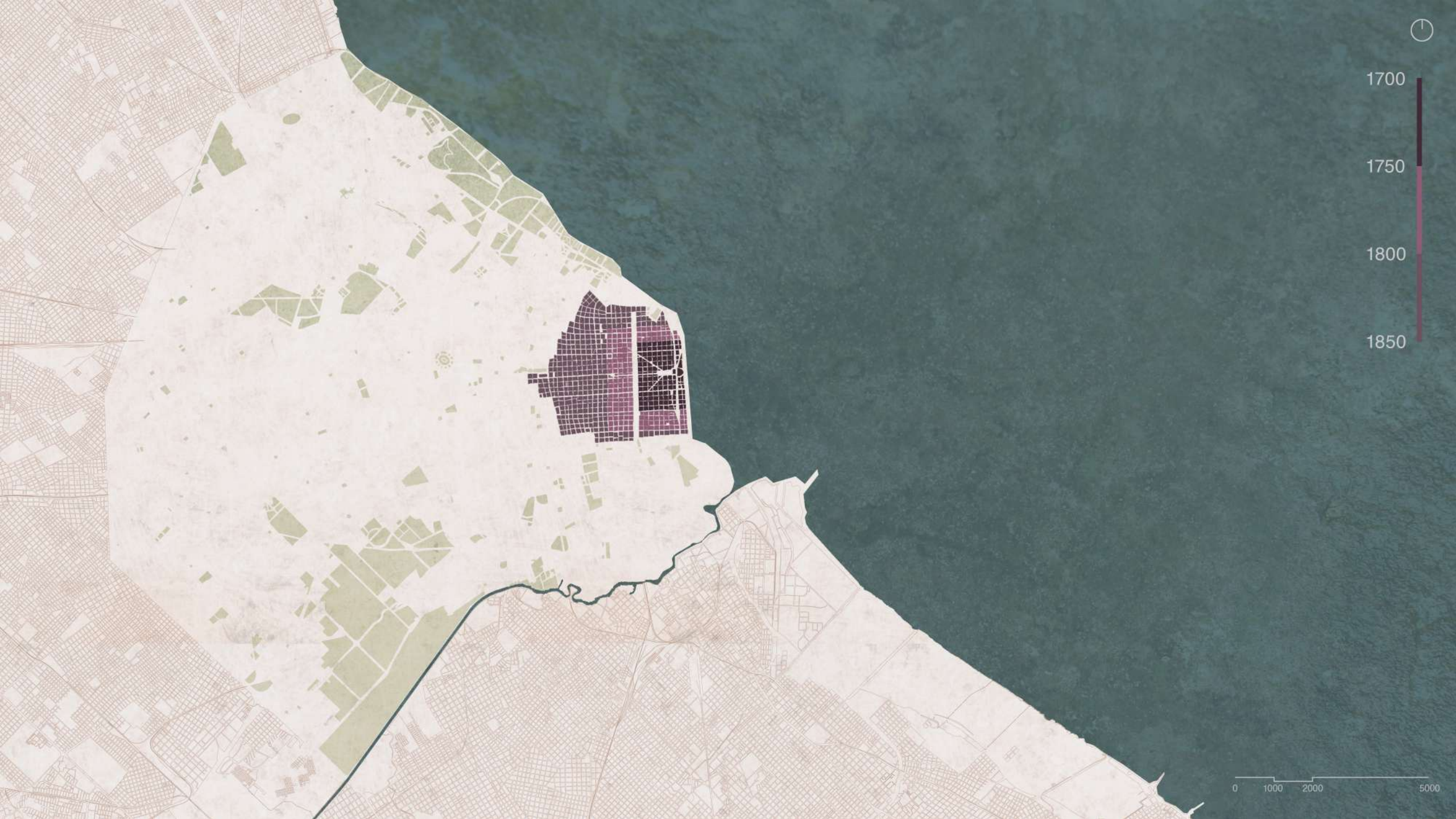

1700
1750
1800
1850

0 1000 2000 5000

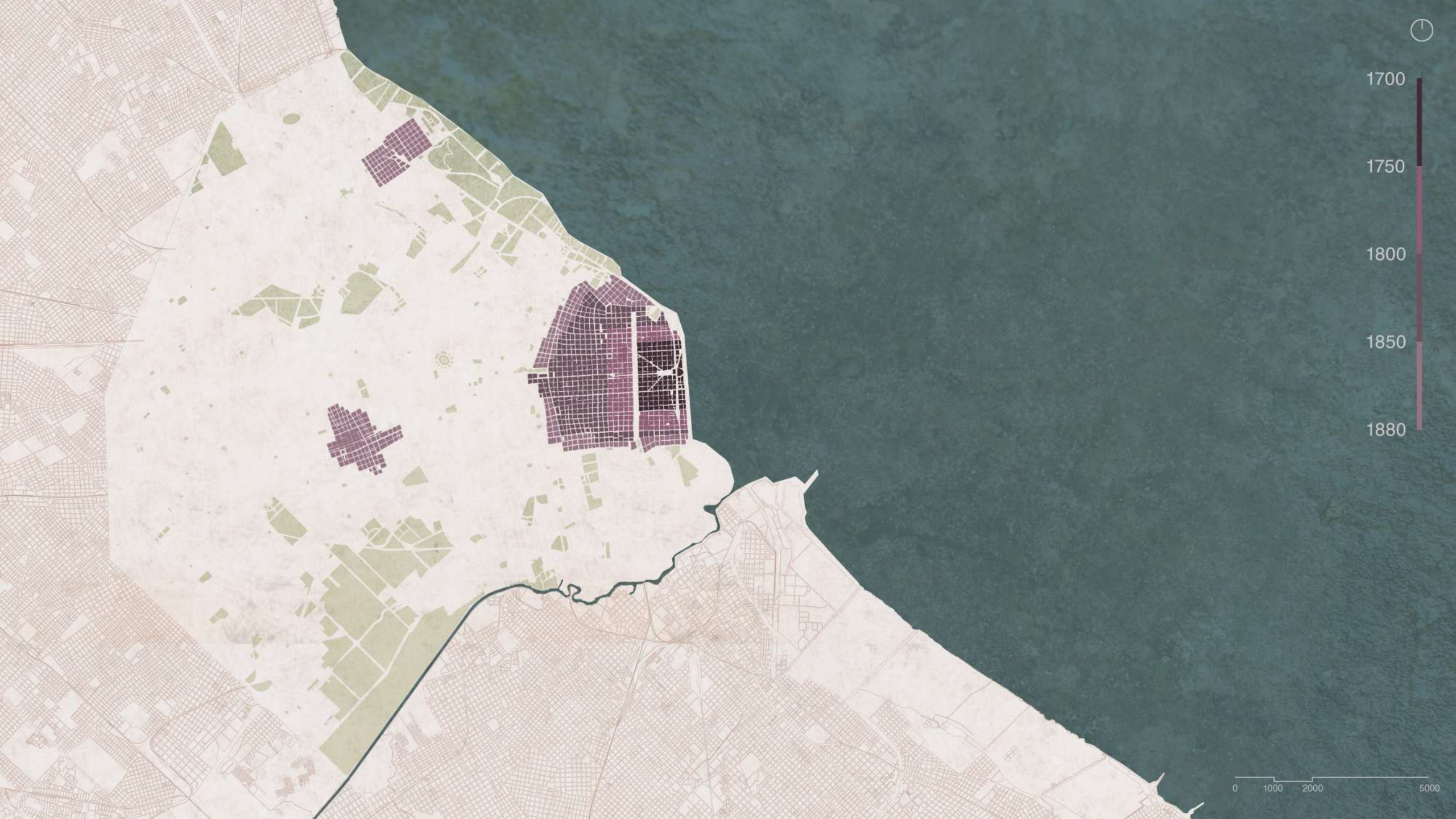

1700
1750
1800
1850
1880

0 1000 2000 5000

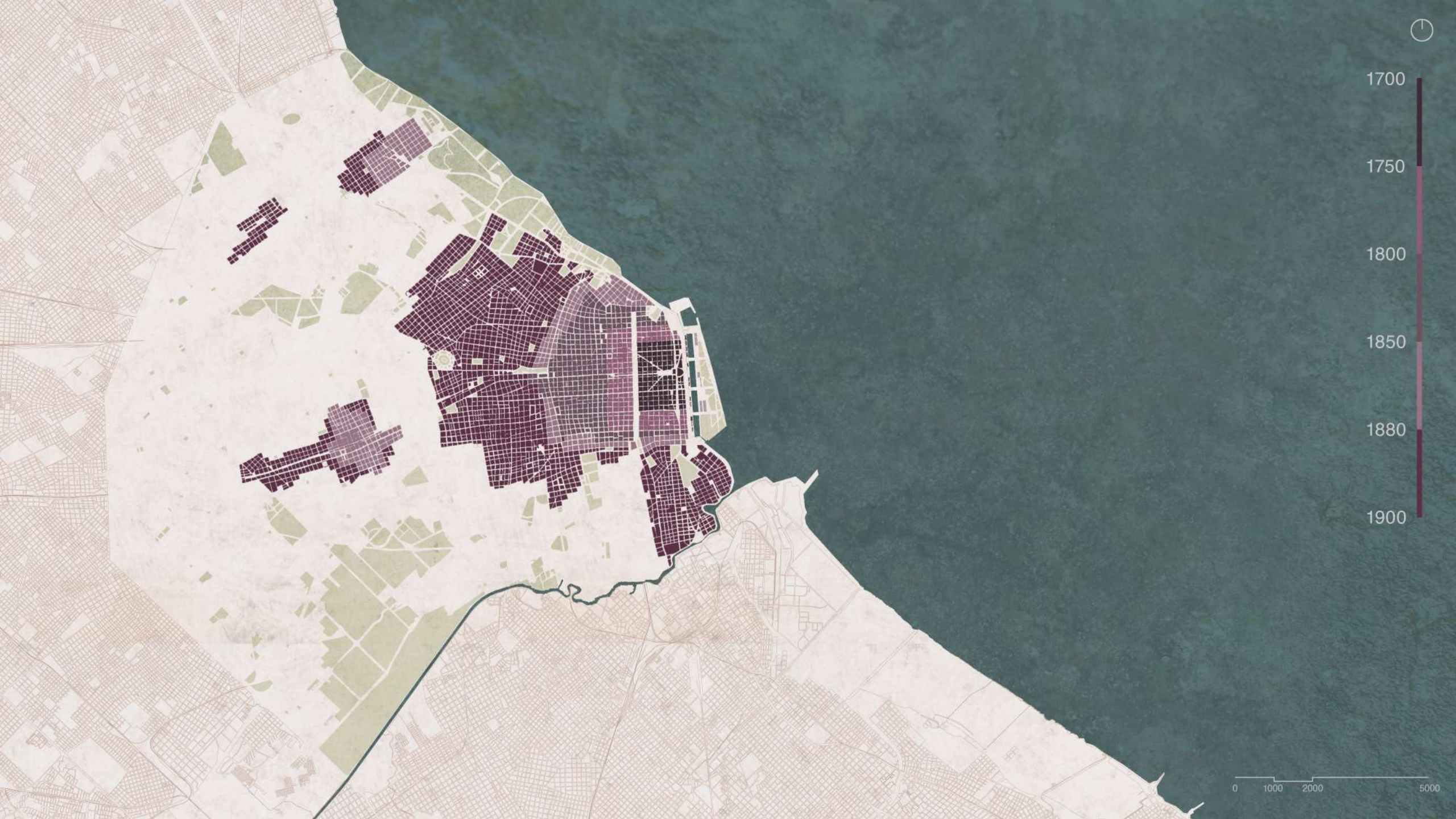

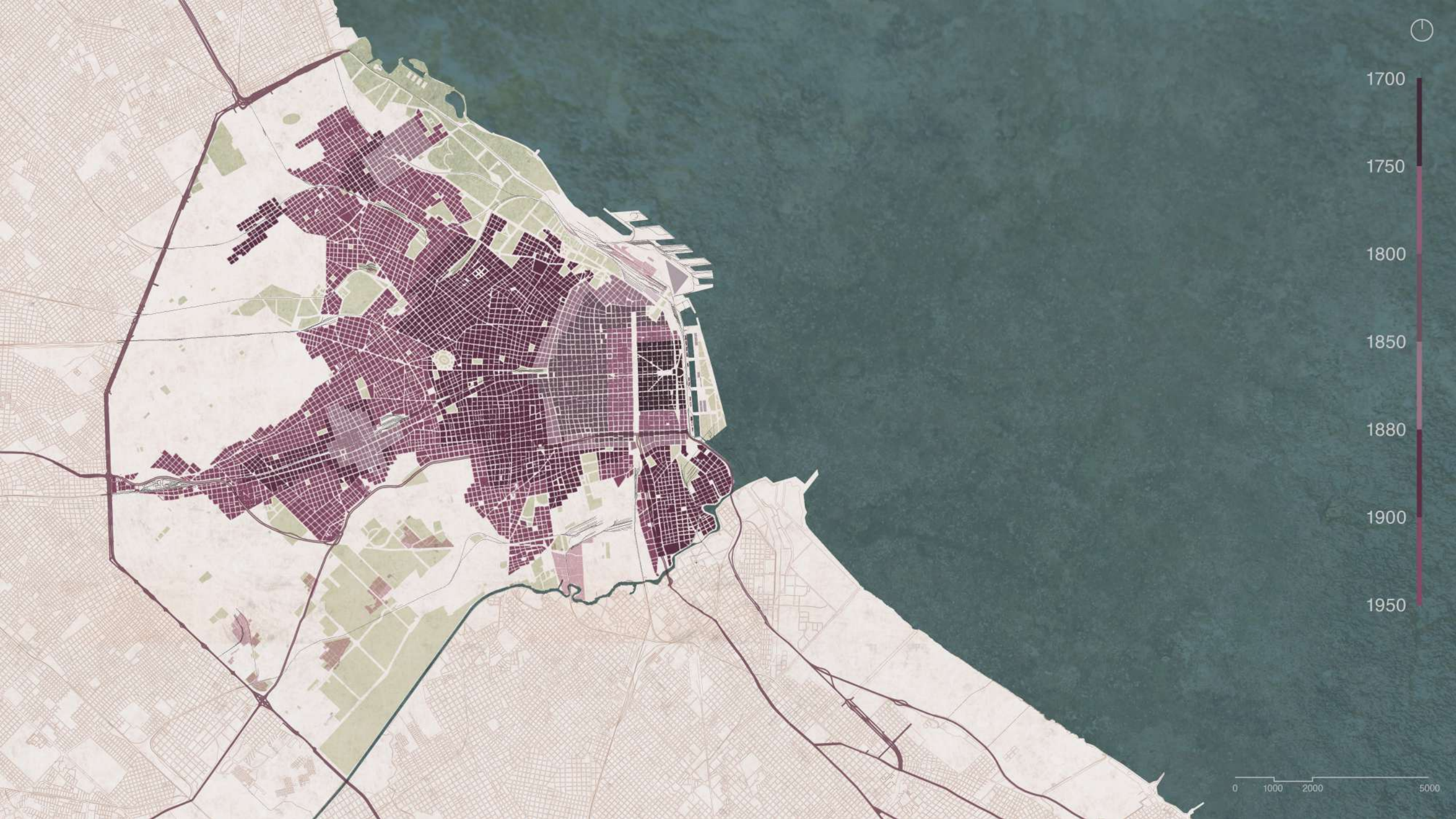

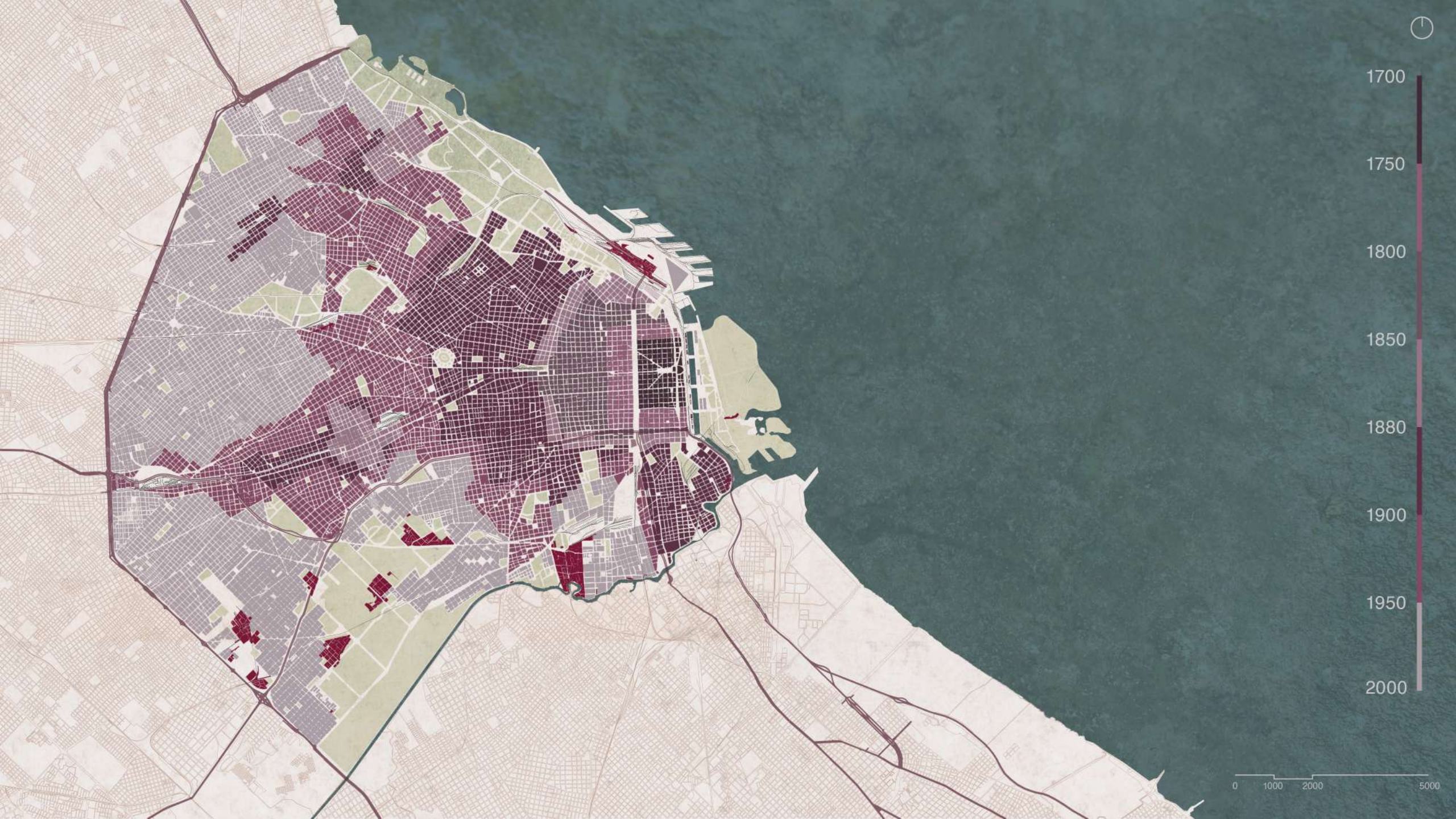

1700

1750

1800

1850

1880

1900

1950

2000

0 1000 2000 5000



IL TESSUTO

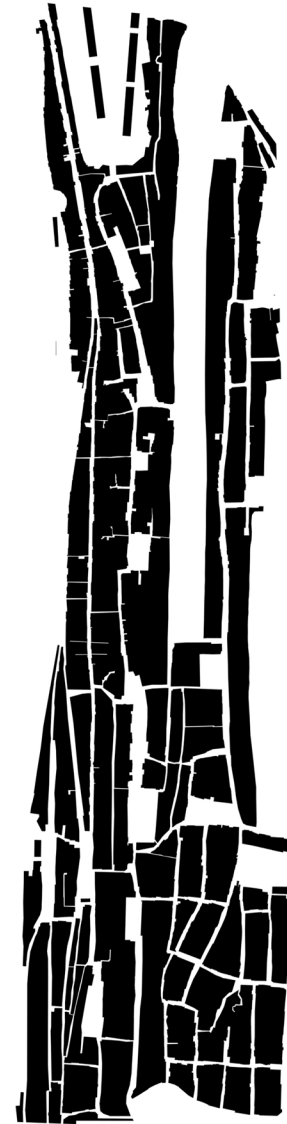
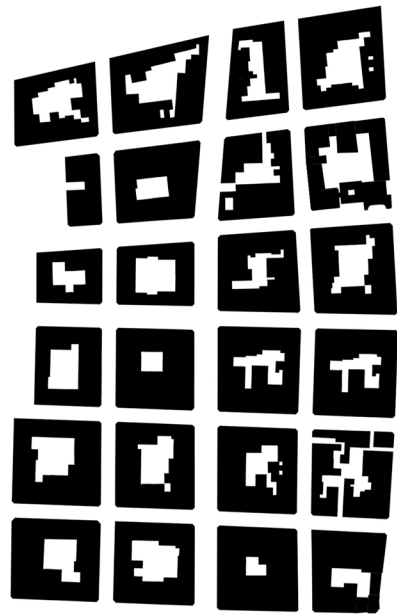

Città formale

Città informale
Villa 31

LA STRADA



Città formale

Città informale
Villa 31

IL VICOLO



Città formale

Città informale
Villa 31

LA PIAZZA



Città formale

Città informale
Villa 31

LA CASA



Città formale

Città informale
Villa 31

1940



0 100 200 500

1965



1974



0 100 200 500

1978



0 100 200 500

1995



0 100 200 500

2000



0 100 200 500



2004



0 100 200 500

2008



0 100 200 500



TRADUZIONE INTERSEMIOTICA



Prima traduzione
(digitalizzazione)

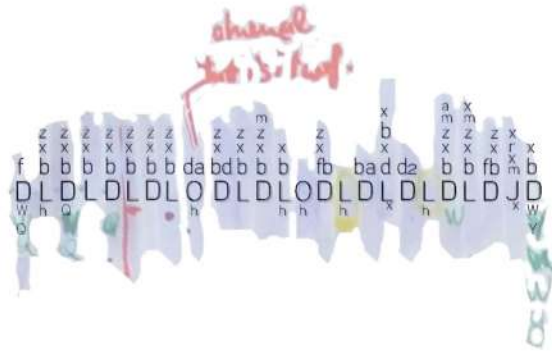

Seconda traduzione
(restituzione analogica)

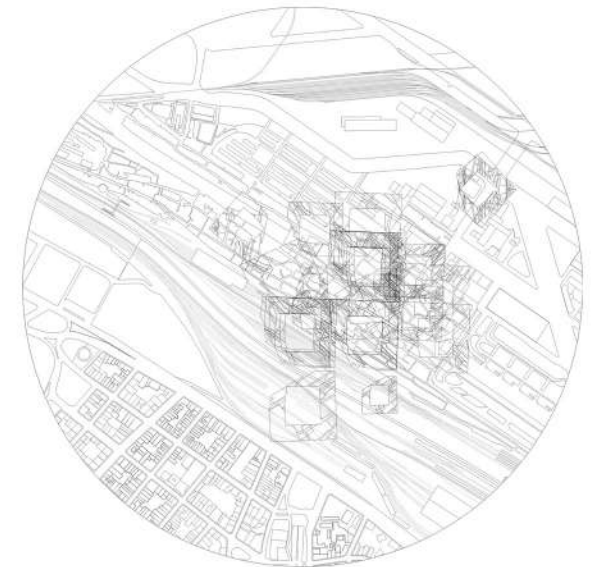
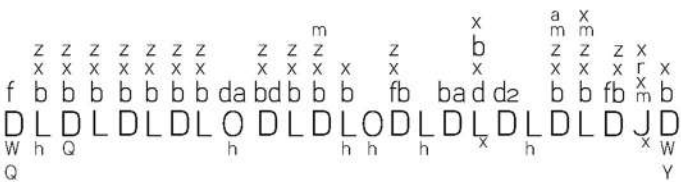



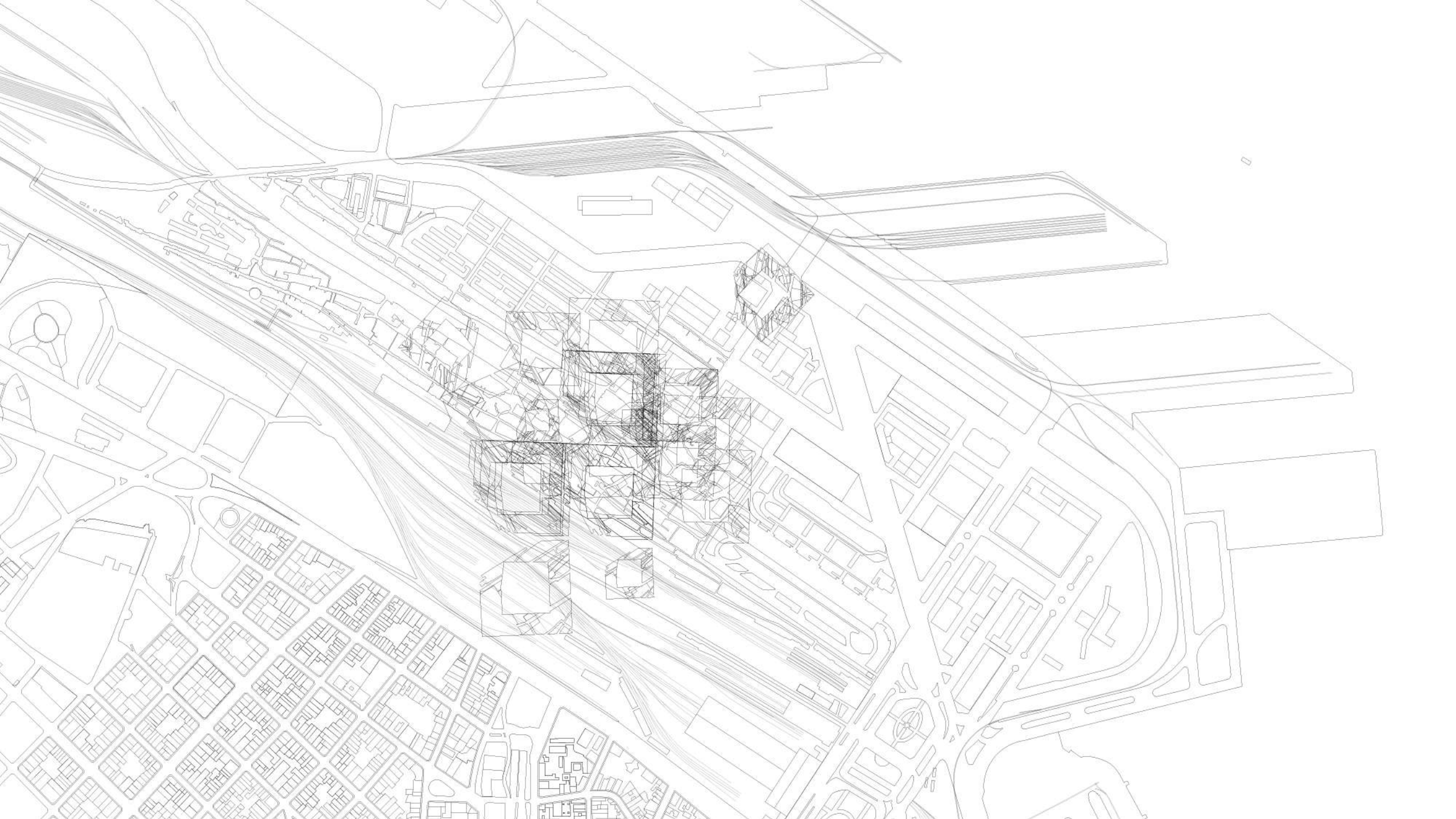

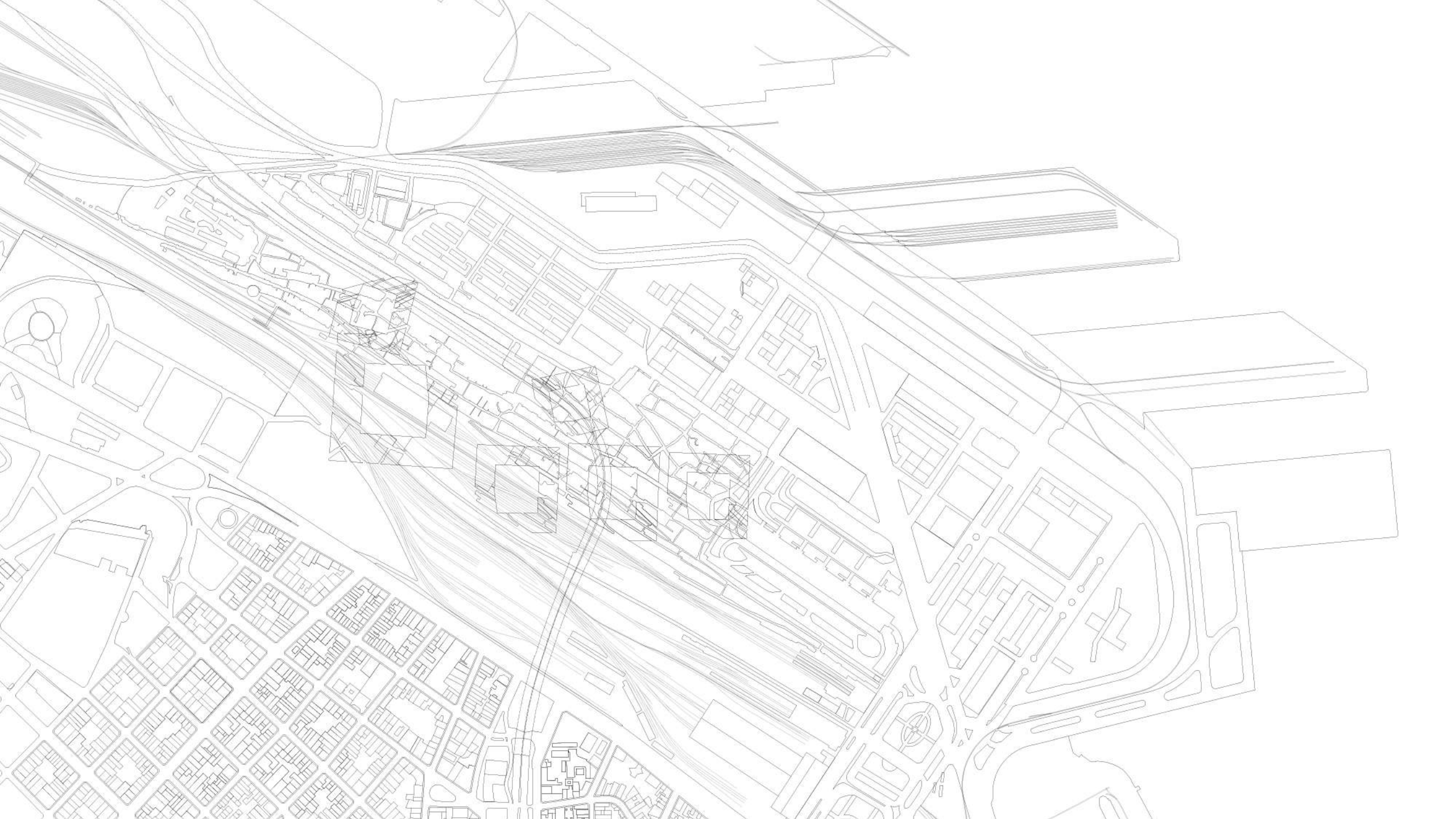

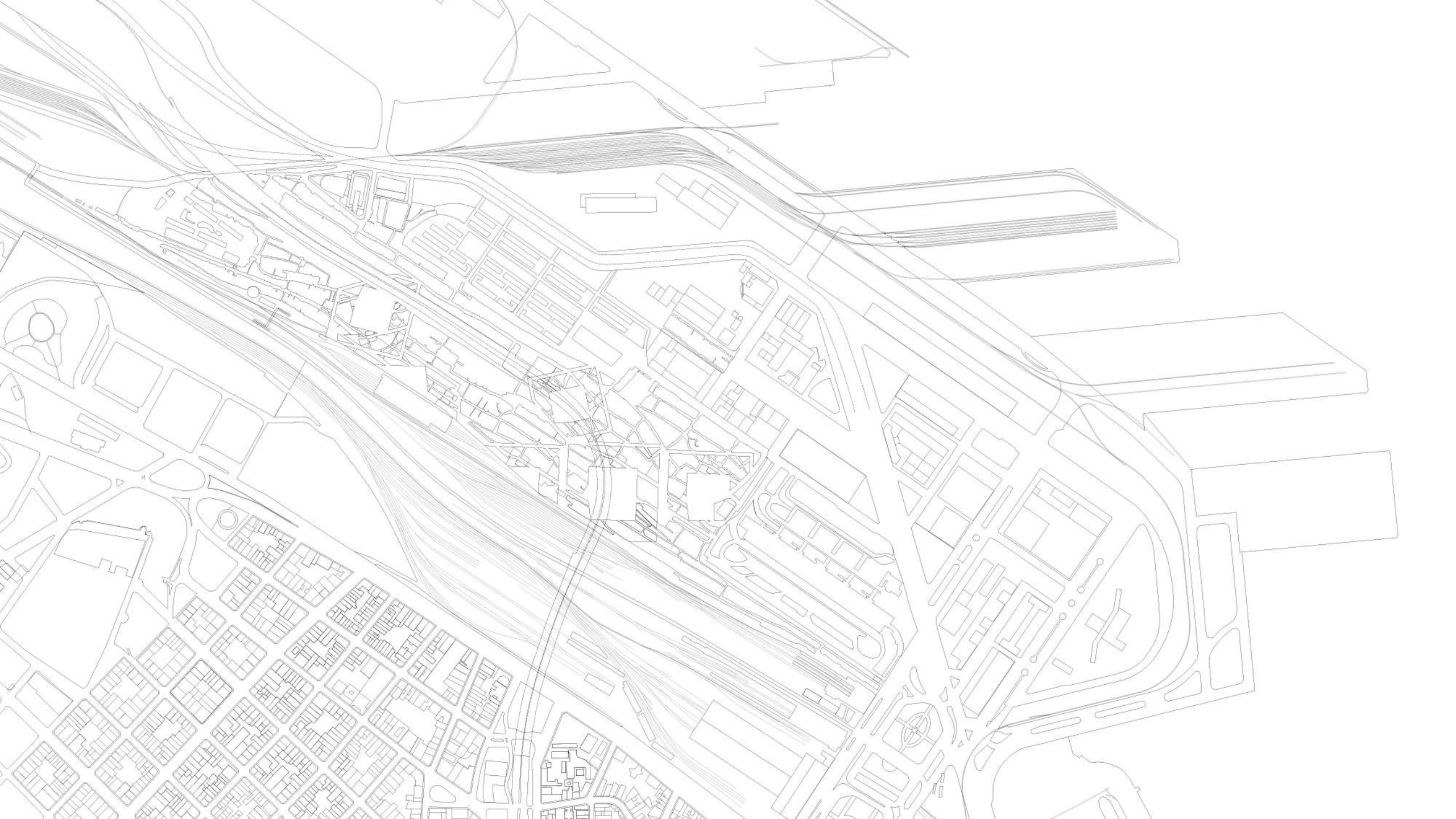

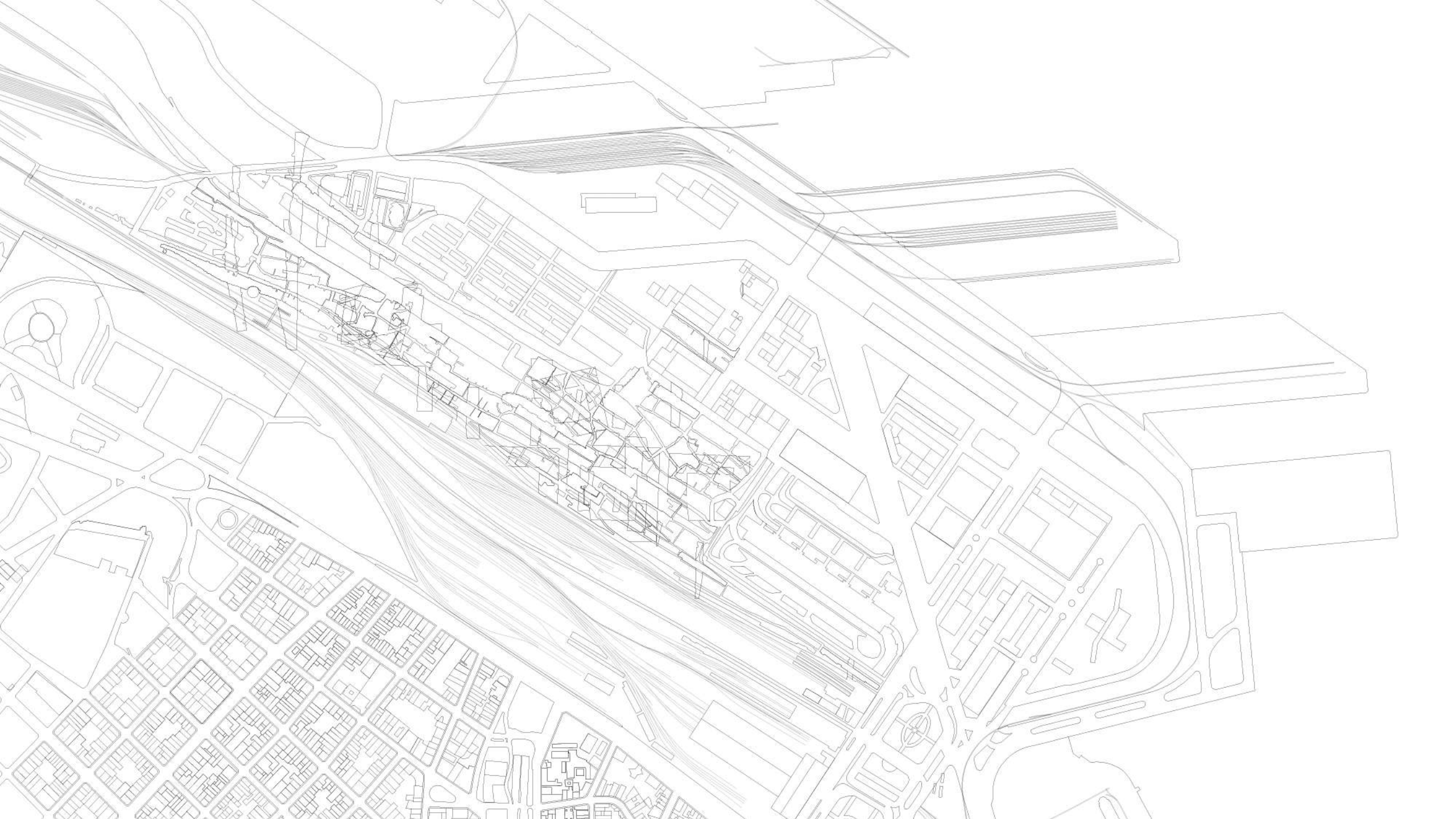

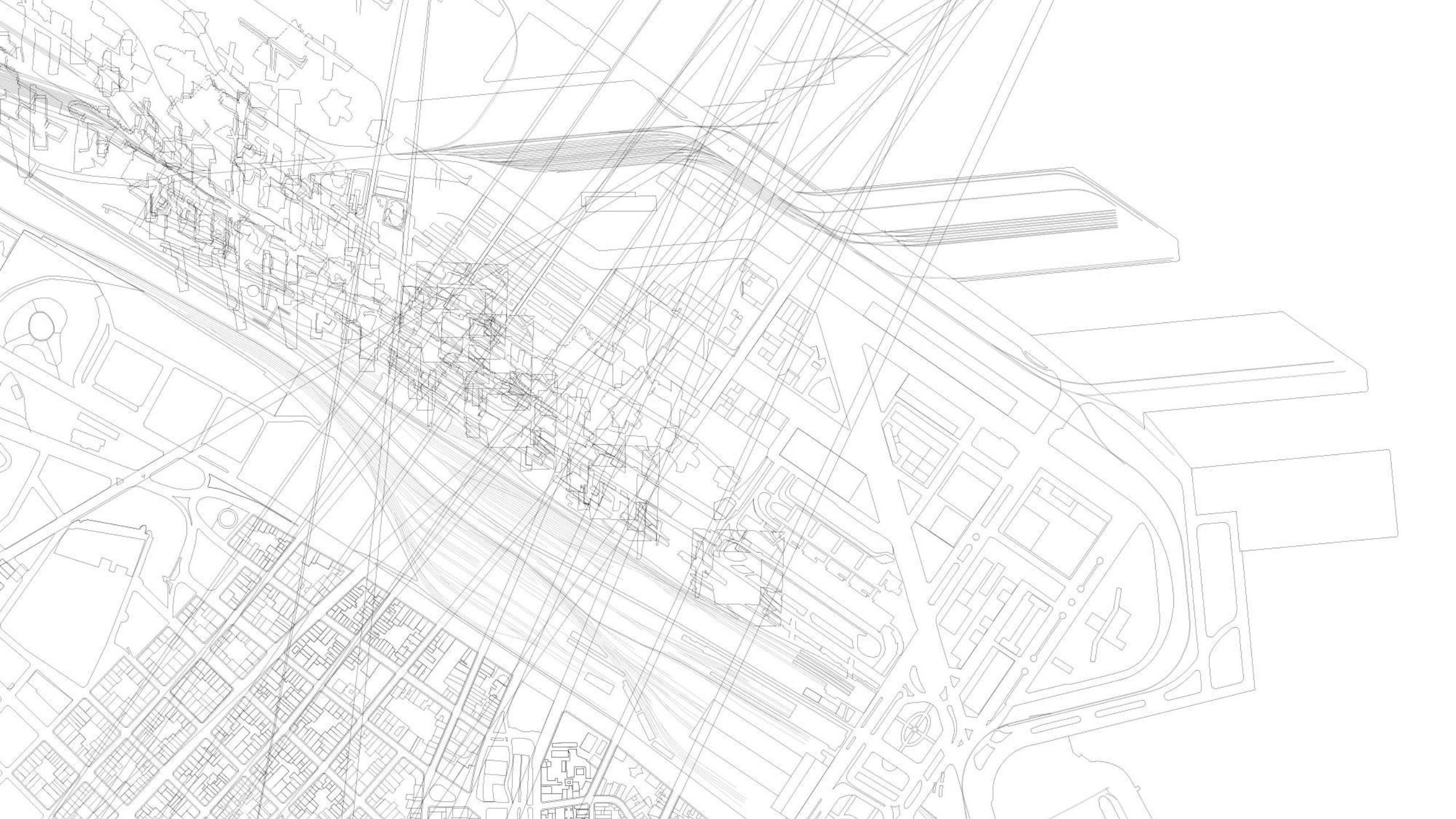



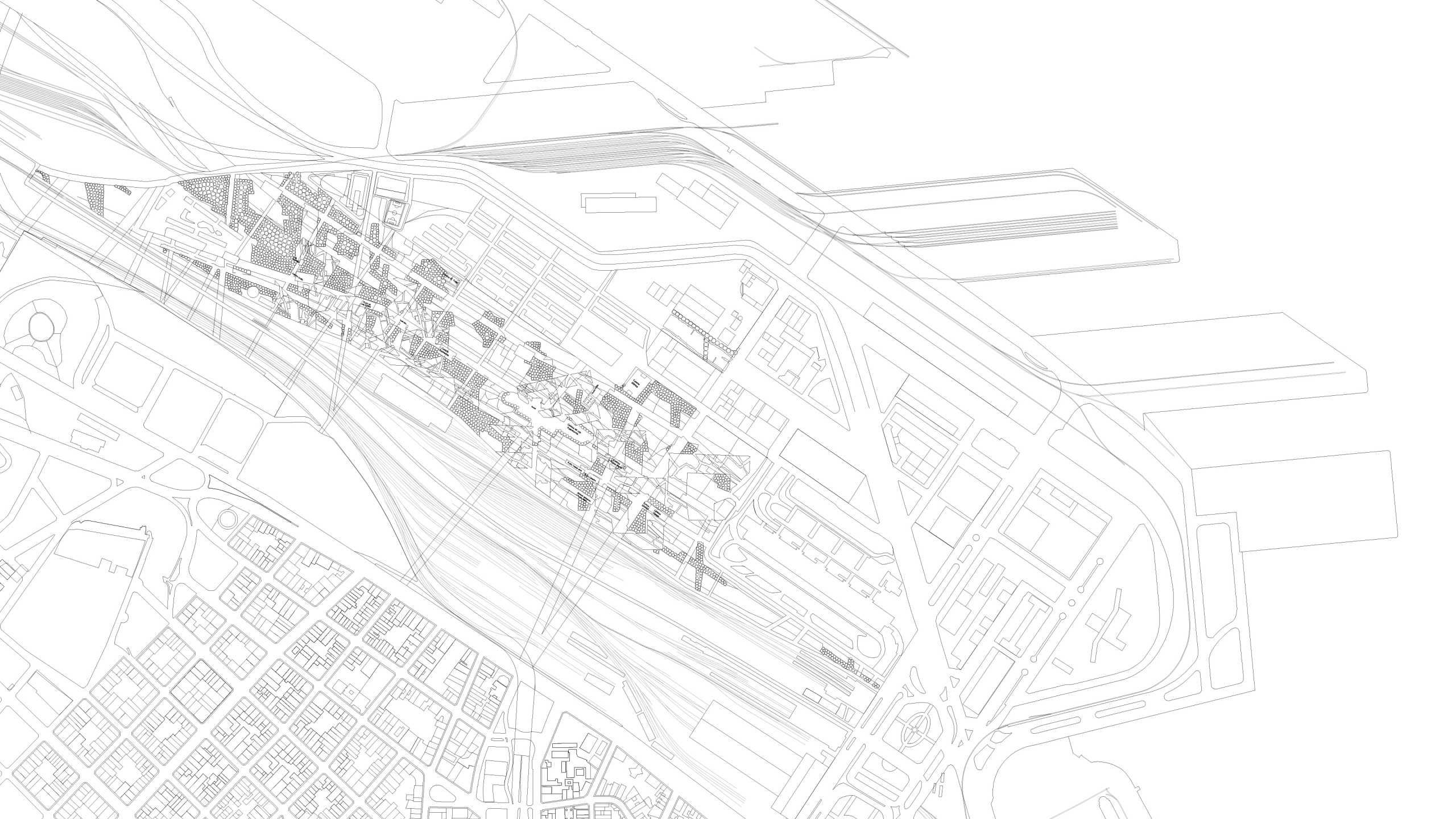







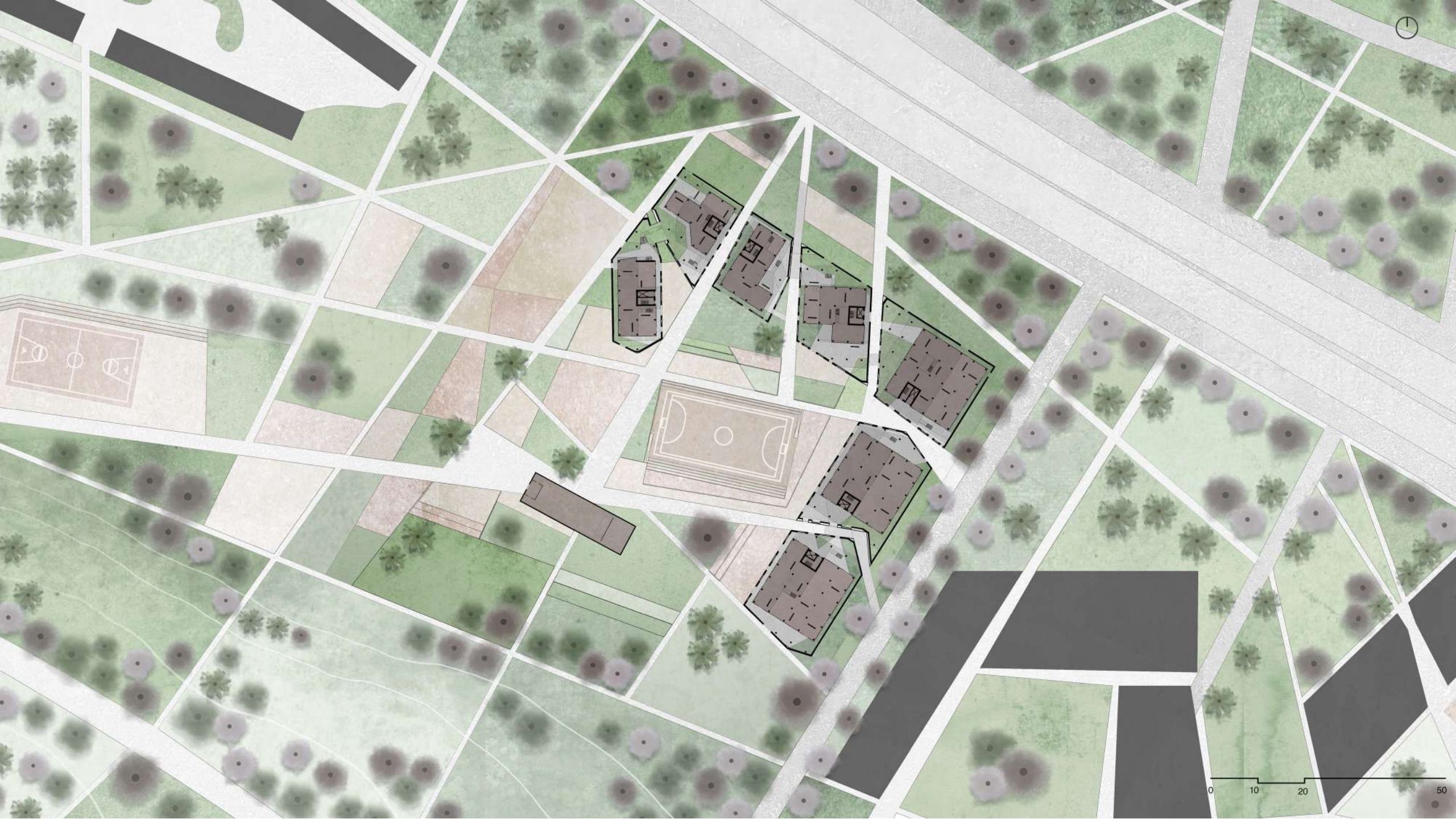

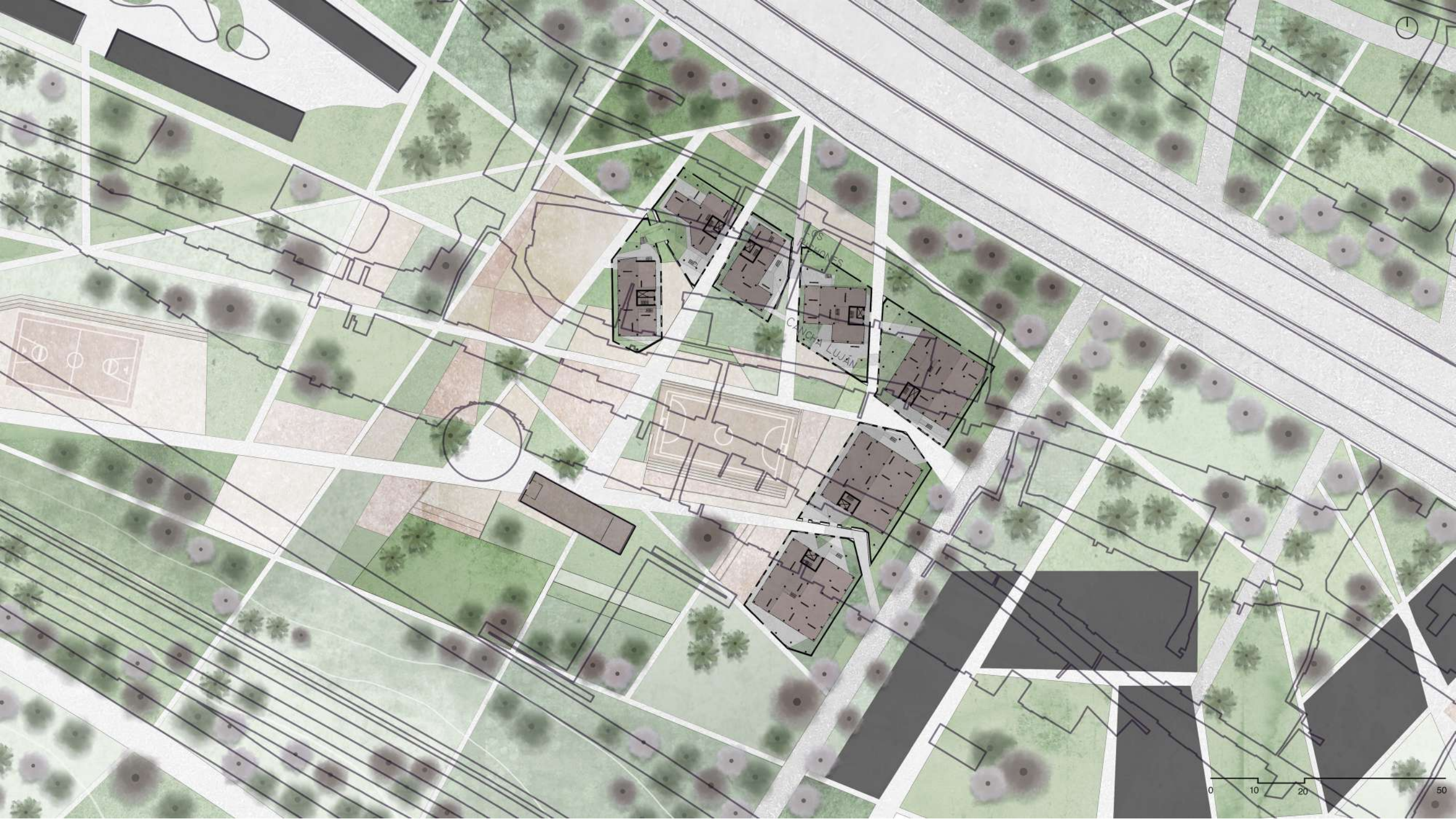

CANCHA LUJAN

0 10 20 50

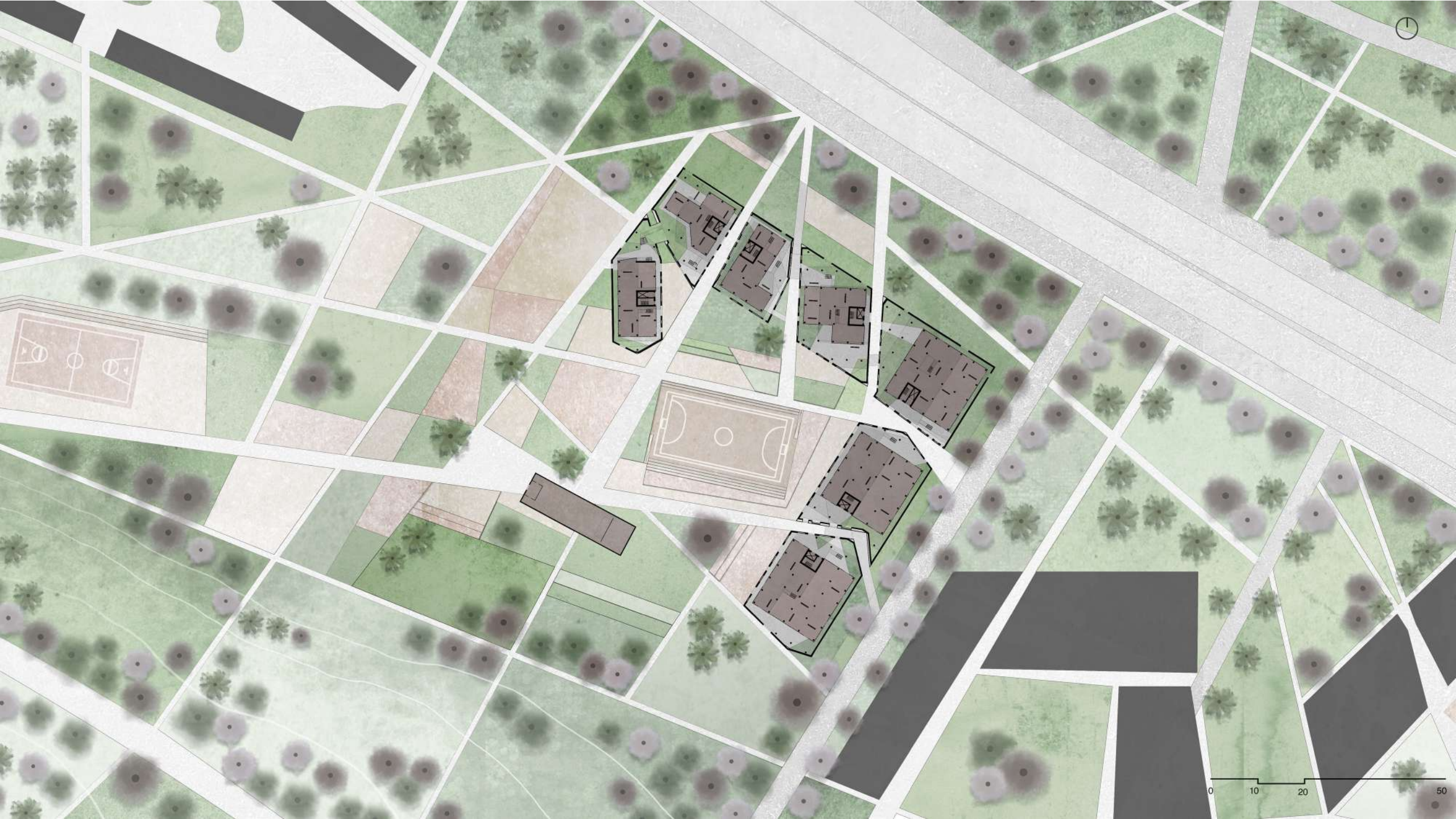

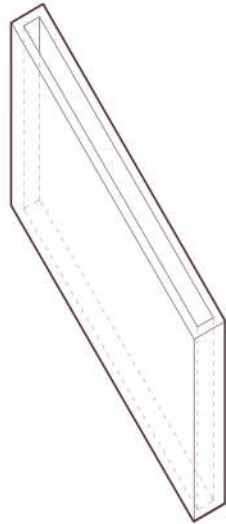
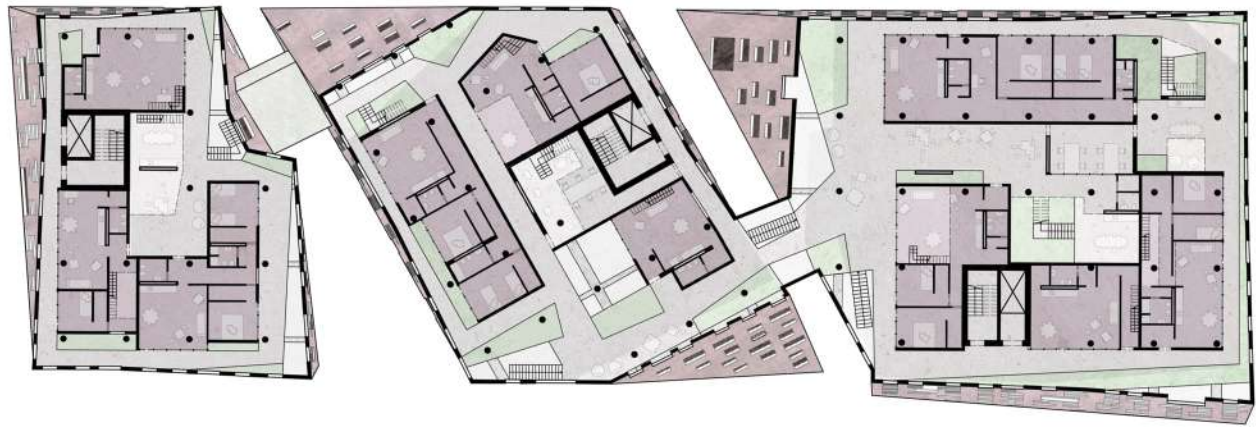

0 5 20 50

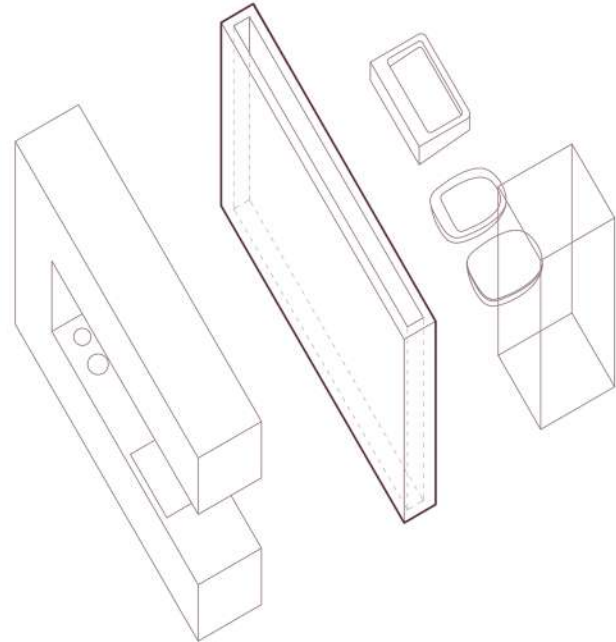
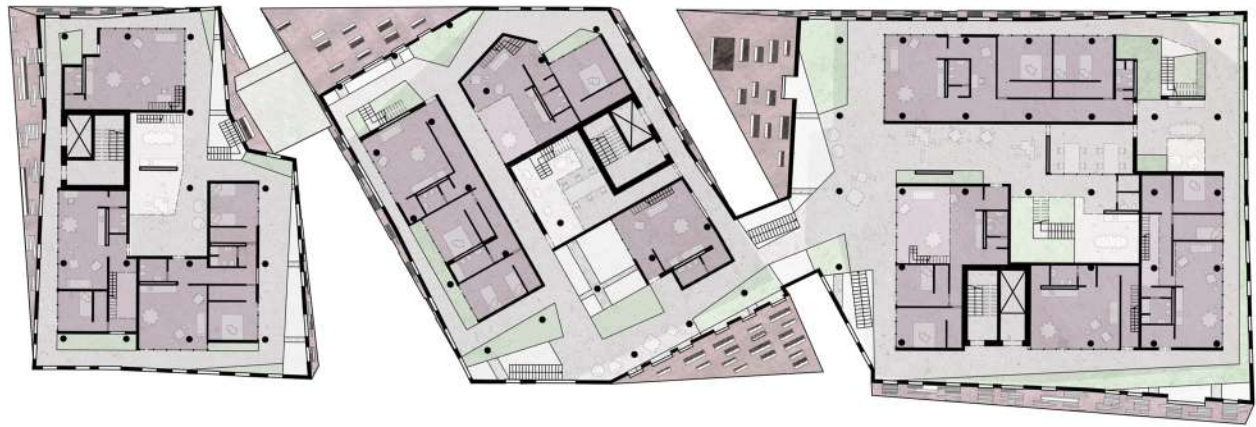

0 5 20 50

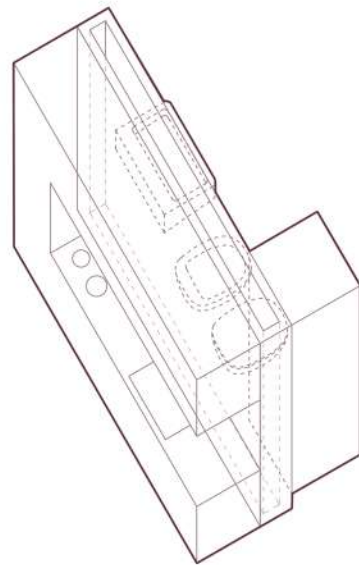
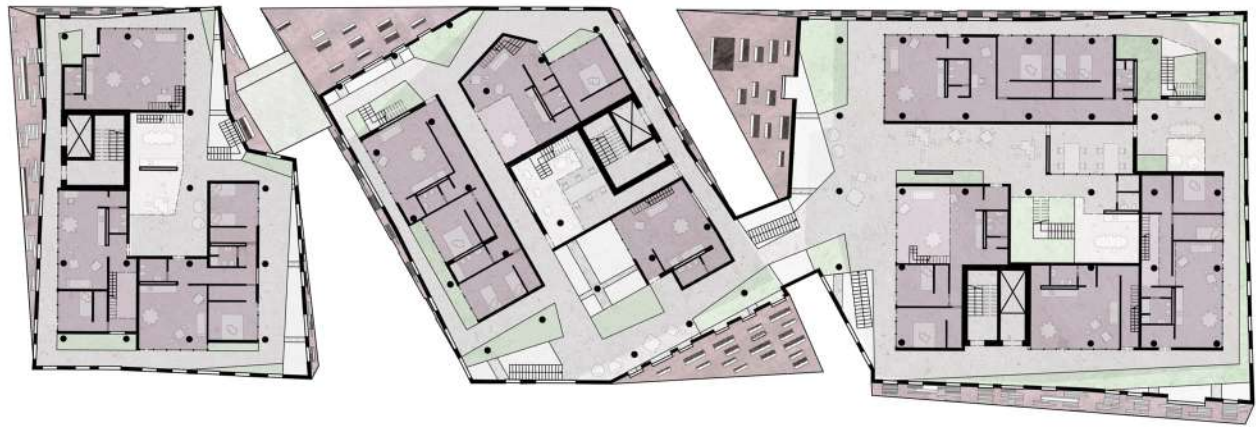

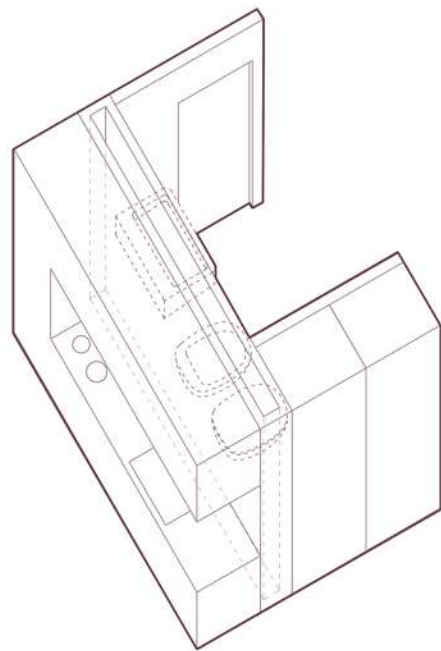
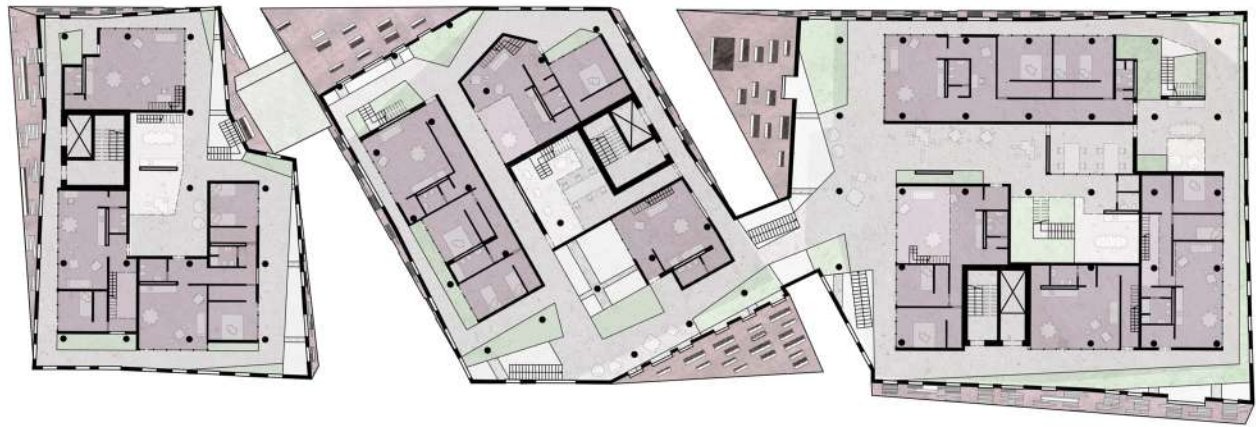

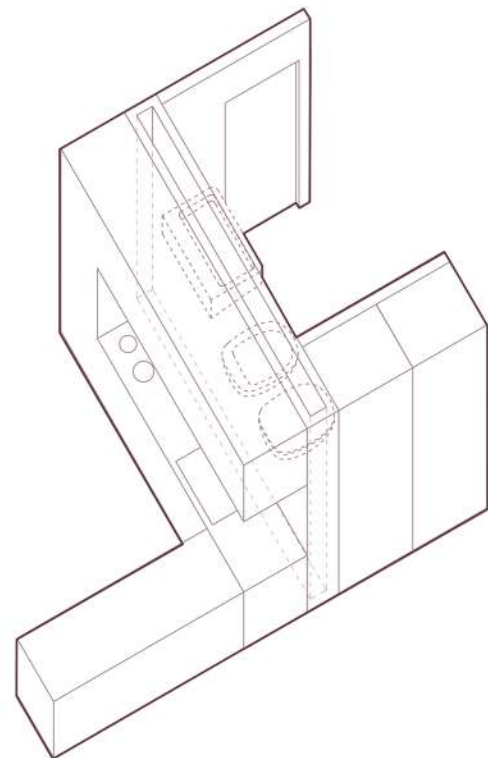
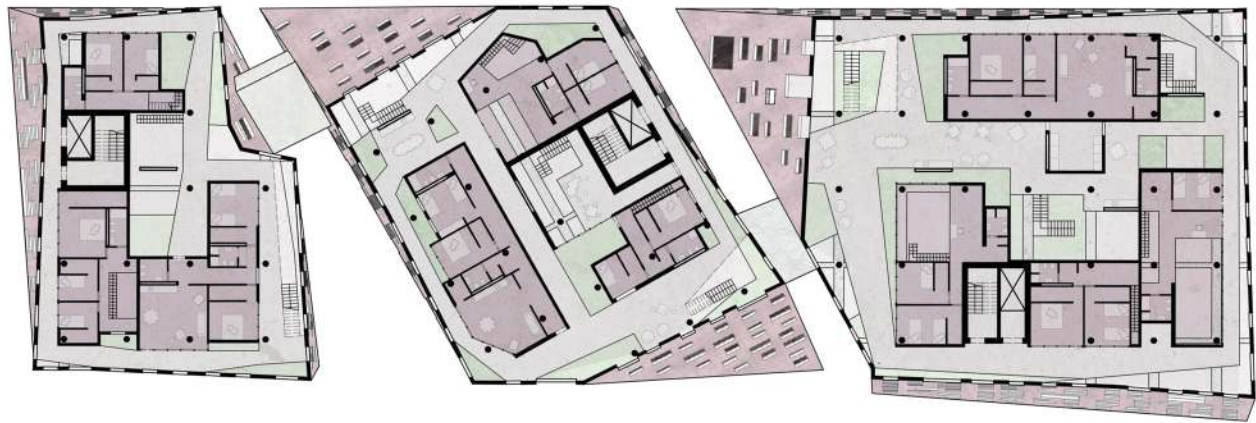

0 5 20 50

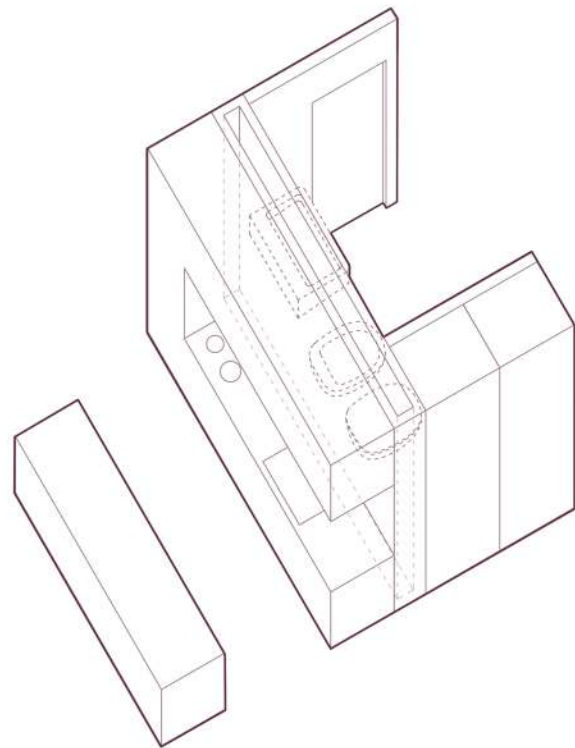
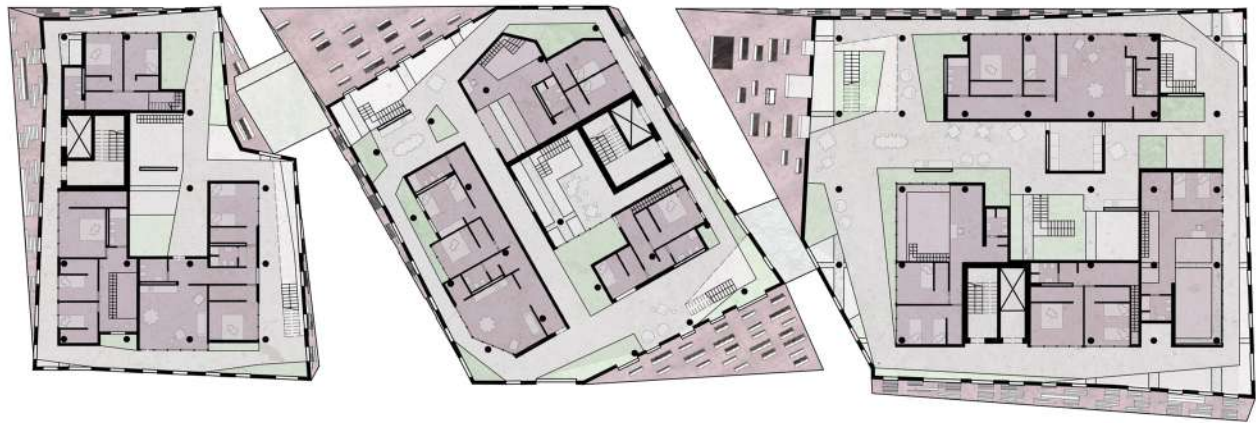

0 5 20 50

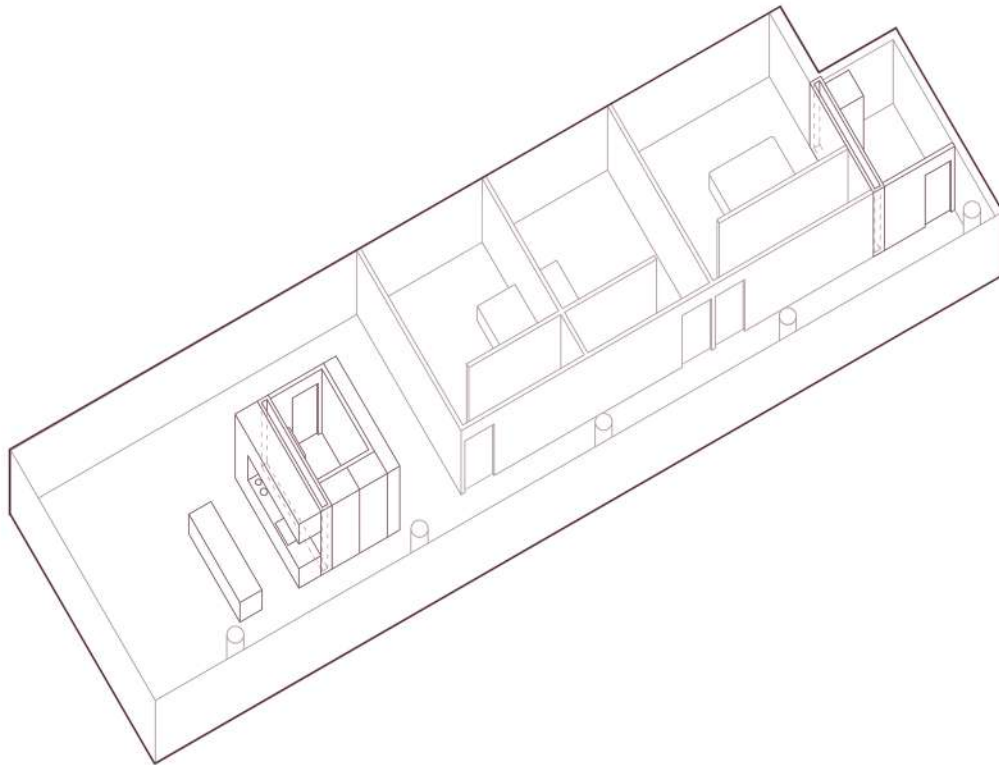
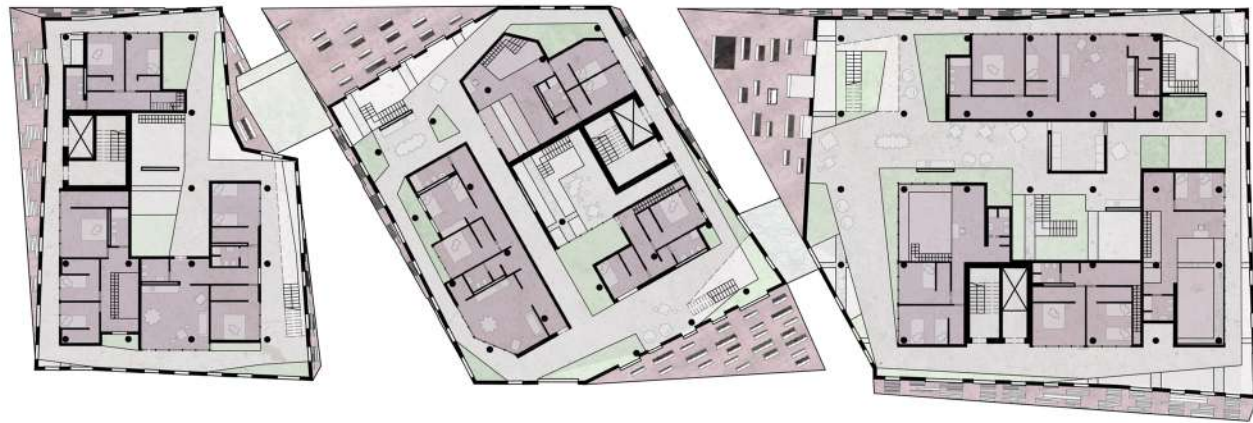

0 5 20 50

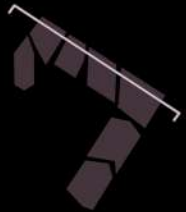



0 10 20 50







