

ALMA MATER STUDIORUM · UNIVERSITÀ DI BOLOGNA

---

Scuola di Scienze  
Dipartimento di Fisica e Astronomia  
Corso di Laurea Magistrale in Fisica

**Generalized hydrodynamics of a class of  
integrable quantum field theories with  
non-diagonal scattering**

**Relatore:**  
Prof. Francesco Ravanini

**Presentata da:**  
Svyatoslav Karabin

Anno Accademico 2017/2018

## Abstract

In questo lavoro di tesi abbiamo analizzato alcuni modelli conformi con perturbazioni integrabili, in particolare il modello di Ising tri-critico e i successivi modelli minimali. Abbiamo costruito un protocollo che realizza questi modelli in un regime fuori dall'equilibrio termodinamico. Questo sistema è stato ottenuto connettendo due sistemi semi-infiniti termalizzati a due diverse temperature. In tempi e spazi grandi ci si aspetta che questo sistema evolva verso uno stato stazionario indipendente dal tempo. Le quantità fisiche di nostro interesse sono le correnti stazionarie generate in tale situazione. Per studiare questo sistema abbiamo utilizzato strumenti di integrabilità come il Bethe ansatz termodinamico, concetti di idrodinamica generalizzata e l'insieme di Gibbs generalizzato. Finora questo schema è stato formulato per le teorie di campo con un'interazione tra le particelle data da una matrice  $S$  diagonale, ovvero per i modelli con lo spettro di quasi-particelle prive di gradi di libertà interni. In questa tesi abbiamo proposto un'estensione di questo metodo a un modello dotato di uno spettro contenente quasi-particelle organizzate in multipletti di simmetrie e quindi dotate di gradi di libertà interni detti magnoni con processi d'urto descritti da matrici  $S$  non diagonali. Abbiamo quindi risolto numericamente le equazioni differenziali che descrivono il sistema di non equilibrio e abbiamo discusso questi risultati.

---

# Contents

---

<b>1</b>	<b>Integrable quantum physics out-of-equilibrium</b>	<b>5</b>
1.1	Quantum steady states . . . . .	6
1.2	Hydrodynamics approach . . . . .	7
1.3	Generalized Gibbs ensemble and Generalized Hydrodynamics . . . . .	10
1.4	Conventional hydrodynamics . . . . .	11
<b>2</b>	<b>Integrability</b>	<b>13</b>
2.1	S-Matrix theory . . . . .	13
2.1.1	S-matrix in (1+1)-dimensions . . . . .	16
2.1.2	Factorization and Yang-Baxter equation . . . . .	18
2.1.3	Two-particle S-matrix . . . . .	20
2.2	Conformal Field Theory: a brief overview . . . . .	23
2.2.1	CFT in 2d . . . . .	24
2.2.2	Radial quantization and Virasoro algebra . . . . .	26
2.2.3	Primary fields and correlation functions . . . . .	28
2.2.4	Hilbert space and highest weight representation . . . . .	29
2.2.5	Unitary models, minimal models and Kac determinant . . . . .	30
2.2.6	Integrals of motion . . . . .	32
2.2.7	Perturbed Conformal Field Theories . . . . .	34
<b>3</b>	<b>Thermodynamic Bethe ansatz</b>	<b>37</b>
3.1	TBA for diagonal S-matrices . . . . .	38
3.1.1	Mirror Thermodynamics . . . . .	40
3.1.2	Thermodynamic limit . . . . .	41
3.1.3	UV and IR limits . . . . .	44

3.1.4	Universal TBA's and Y-systems . . . . .	46
3.2	TBA for non-diagonal S-matrices . . . . .	49
3.2.1	Trigonometric S-matrix . . . . .	50
3.2.2	Thermodynamics . . . . .	53
<b>4</b>	<b>Non-equilibrium Thermodynamic Bethe Ansatz</b>	<b>61</b>
4.1	Generalized Thermodynamic Bethe Ansatz . . . . .	61
4.2	Conformal Field Theory out-of-equilibrium . . . . .	62
4.3	GGE via quasi-particles . . . . .	63
4.4	Euler equation . . . . .	65
4.5	Riemann problem . . . . .	67
<b>5</b>	<b>GHD for perturbed minimal models</b>	<b>69</b>
5.1	Tricritical Ising Model: general features . . . . .	69
5.2	GHD and TBA for TIM . . . . .	71
5.3	Partitioning protocol and numerical analysis . . . . .	74
5.4	Generalization to minimal models . . . . .	78
<b>6</b>	<b>Conclusions and perspectives</b>	<b>81</b>
<b>A</b>	<b>Thermalization in closed many body quantum systems</b>	<b>83</b>
<b>B</b>	<b>Euler equations calculations</b>	<b>85</b>
<b>C</b>	<b>Lie algebras</b>	<b>87</b>
	<b>References</b>	<b>90</b>

---

## Introduction

---

Many-body quantum systems out-of-equilibrium represent one of the most important challenges of modern theoretical physics. Non-equilibrium situations are as common in nature as equilibrium ones. Consequently, the challenge is to find a physical “toolbox” for such situations. One of the most interesting targets is to understand and describe how a non-equilibrium system reaches a time independent steady-state.

In recent years, there has been a surge of interest in non-equilibrium dynamics of (1+1)-D isolated systems. In part this is due to the realization of cold atom and ultracold atom experimental techniques [1, 2] which make possible to reproduce such systems in a controlled way. Indeed, contrary to usual solid state experimental setup where it was impossible to separate a system from its environment, in the new cold atoms experiments it is possible to minimize the coupling. This new empirical advancement gives a possibility to study a quantum unitary evolution of a system and to observe new physics. In particular, the optical lattices experiments allow to reproduce solid state lattice and to access to the many body physics. Such systems can be realized as lattices of different dimensions and with different interactions.

The objects of interest of this thesis are the current-carrying steady states which give rise to heat and particle constant flows in (1+1)-D field theories systems. Many, (1+1)-D systems turn out to be exactly solvable (or integrable). A system is said to be integrable when it admits a number of commuting conserved charges equal to the number of degrees of freedom. It means that we can obtain all energy eigenstates and eigenvalues, and correlation functions of local operators. There are a lot of techniques that allow to solve integrable models, for example Algebraic Bethe ansatz for spin chains and S-matrix factorization which leads to thermodynamic Bethe ansatz (TBA) for massive quantum field theories. However, these methods are used to describe statistical models of (1 + 1)-D systems at equilibrium i.e. homogeneous and stationary systems. In the absence of homogeneity, most of the standard integrability tools are broken. However, these

standard structures may be recovered using the idea of emergence of hydrodynamics.

In equilibrium statistical mechanics the probability of a microstate of a system in equilibrium with thermal reservoir is given by Gibbs distribution so the system described by an Hamiltonian  $\mathcal{H}$  has the probability distribution over the configuration space proportional to  $\exp(-\beta\mathcal{H})$  with  $\beta = 1/kT$ . For a system out-of-equilibrium, the probability of a given microstate evolves with time. In a long time limit the system may thermalize and the probability may converge to a constant distribution. In this situation the system may admit a particle or energy current between two parts of the system.

The dynamics of  $(1 + 1)$ -D non-equilibrium integrable quantum systems differs consistently from the dynamics of higher dimensional systems because of the presence of an infinite number of conservation laws. It is widely believed that a  $(1 + 1)$ -D integrable system is not described by a canonical density matrix, but by a generalized Gibbs ensemble that takes into account an infinite set of commuting integrals of motion  $\mathcal{I}_i$ :  $\rho = \exp(-\sum_i \mathcal{I}_i \beta_i)$ , where  $\beta_i$  are sort of generalized inverse temperatures.

In this work we will employ the TBA, the concept of generalized Gibbs ensemble and the generalized hydrodynamics to study the out-of-equilibrium dynamics of integrable  $(1 + 1)$ -D quantum field theory systems . We will apply these tools to a setting where two systems, initially prepared in a homogeneous equilibrium state, at two different temperatures, are joined together at a given time  $t_0$ . We expect that the system evolves to the time independent steady state which presents non vanishing currents of some observables. This type of construction is named partitioning protocol. By using these techniques it is possible compute the thermodynamics of the models with diagonal S-matrix.

The main aim of this work is to investigate the non-equilibrium steady states in the case of integrable field theories with non-diagonal S-matrices and to compute the currents of the conserved quantities.

The thesis is organized as follows:

- In Chapter 1 we introduce the problem of bipartite system and describe how a system reaches non-equilibrium steady states. These kind of systems, at certain scales, can be described by the hydrodynamic theory where the crucial role is played by the Euler equation. Moreover, in the case of systems with infinitely many conserved local charges, the standard hydrodynamic should be modified in order to take into account all these conserved quantities. However, to describe non-equilibrium steady states, local conserved charges are not enough so we need to consider also quasi-local conserved charges. The corresponding hydrodynamic theory are very complicated because we have an Euler equation for each local and non-local conserved charge. This problem can be managed by recasting the problem in the quasi-particle language. And by using the standard integrability tools, in particular, the Thermodynamic Bethe ansatz.

- In Chapter 2 we review the general, standard S-matrix theory in (1+1)-dimensional integrable models. We will discuss the role of integrability in the factorization scattering process, analytical properties of S-matrix and the bootstrap principle. Knowing the exact S-matrix of a model is crucial in order to obtain the thermodynamic Bethe ansatz equations. In the second part of the chapter we briefly review the Conformal Field Theory and we explain how a Perturbed Conformal Field Theory can be constructed. Understanding of these arguments is crucial since the model under our analysis is a perturbed conformal model.
- Chapter 3 is entirely dedicated to the study of the *thermodynamic Bethe ansatz* (TBA). In the first part of the chapter we present the TBA for the theories with diagonal S-matrix, as was described by A.L.B. Zamolodchikov in [25]. In the second part of the chapter we will study the TBA with non-diagonal S-matrix. In particular, we will derive the TBA equations for a large class of perturbed coset models which include perturbed minimal models. In this case the computation of TBA equations is complicated by the fact that we have to use some techniques of algebraic Bethe ansatz. The resulting TBA equations are different from the diagonal ones because magnonic degrees of freedom appear.
- In Chapter 4 we describe the generalization of TBA to the case where the system's density matrix contains a large number of conserved quantities. The solution of the TBA, in the case of known steady state density matrix, encode all information needed to describe the thermodynamics of the system and to characterize all currents emerged in the non-equilibrium system. The main challenge is to evolve the initial density matrix to the steady state density matrix. We will see that in the case of a bipartite systems, the generalized TBA describing a non-equilibrium steady state, can be obtained by using the recently proposed framework called generalized hydrodynamic approach. In this chapter we present how the generalized hydrodynamic works in the case of field theory with diagonal scattering.
- In Chapter 5 we will discuss the enlargement of the hydrodynamic approach to the case of integrable field theories with non-diagonal scattering. In particular, the case of tricritical Ising model will be studied and solved numerically. In this case the non diagonal nature of the scattering implies that the density matrix of the steady-state system must be characterized also by the magnonic structure of the model. This yields to significative modifications of the standard TBA equations and of the Euler equations.

# CHAPTER 1

---

## Integrable quantum physics out-of-equilibrium

---

In this chapter we present the basic ingredients of non-equilibrium isolated quantum systems and explain how this kind of system can be constructed. We will study systems obtained using the so-called partitioning protocol. This construction consists in putting together two independently thermalized systems, at two different temperatures. This gives rise to current-carrying non-equilibrium steady states in the total system. We will see that at large time and large space, in this system, the hydrodynamics becomes relevant and the conserved quantities of the system satisfy the Navier-Stokes equations. In case of partitioning protocol the set of differential equations with initial boundary condition is known as Riemann problem. The solution of this problem represent a complete characterization of non-equilibrium steady state.

So, we will study how the hydrodynamics emerges in general non-equilibrium systems and integrable systems. The hydrodynamic ideas represent the novel framework for studying transport and relaxation in non-equilibrium systems. The hydrodynamics works at the Euler scale, scale at which variation between densities of local quantities is small and the system is composed by mesoscopic fluid cells depending on space-time coordinates  $(x, t)$ . Each fluid cell contains a large number of microscopic quantities. The case of integrable systems is very interesting, because the presence of an infinite set of conserved charges constrains the system to reach a steady state.

It is believed that the steady state system should be described by *Generalized Gibbs Ensemble* (GGE). A GGE is an ensemble which is constructed with a larger or infinite number of local and quasi-local conserved charges, not just energy and particle number as in Gibbs ensemble. In the context of integrable models the hydrodynamics should consider all conserved quantities. The resulting theory is named *Generalized Hydrodynamics* GHD.



## 1.1 Quantum steady states

The systems presenting non-equilibrium steady states [3, 4] (states with flows of energy or other quantities) can be obtained employing various approaches. The two most relevant categories are

- effective reservoirs approach: the system under consideration is connected to external reservoirs or baths. In this case the system is open and there is the flow of energy or particles between the system and the external reservoir. The dynamic of the system is non-unitary, but dissipative.
- Hamiltonian reservoir approach: it consists in englobing the system and the baths into a “total system”. In this case the dynamics is unitary and the system is close.

In this work we adopt the second method which is based on unitary evolution of the total system. The system, under our consideration, is obtained in the following way (see Figure 1.1):

1. First we prepare two semi-infinite halves of a homogeneous 1-d quantum system thermalized independently at temperatures  $T_L$  and  $T_R$ .
2. At a given time, one connects the two halves so that they can exchange energy or particles.
3. The initial state  $|ini\rangle$  will be evolved with the total Hamiltonian  $H$  and at the large time is expected that the system reaches a steady regime.

So, mathematically the steady state limit is given by:

$$\mathcal{O}^{\text{sta}} := \lim_{L \rightarrow \infty} \lim_{t \rightarrow \infty} \langle e^{iHt} \mathcal{O} e^{-iHt} \rangle_{ini} \quad (1.1)$$

where  $\mathcal{O}$  is some local observable.

For example, consider the Heisenberg spin chain with local interactions of length  $2L$ , with Hamiltonian

$$H = \sum_{i=-L}^L h_i, \quad h_i = \vec{\sigma}_i \cdot \vec{\sigma}_{i+1}. \quad (1.2)$$

where  $\vec{\sigma}_i$  is a Pauli vector which acts non trivially on the site  $i$ . Suppose this system is initially broken into two halves

$$H_l = \sum_{i=-L}^{-1} h_i, \quad H_r = \sum_{i=1}^L h_i. \quad (1.3)$$

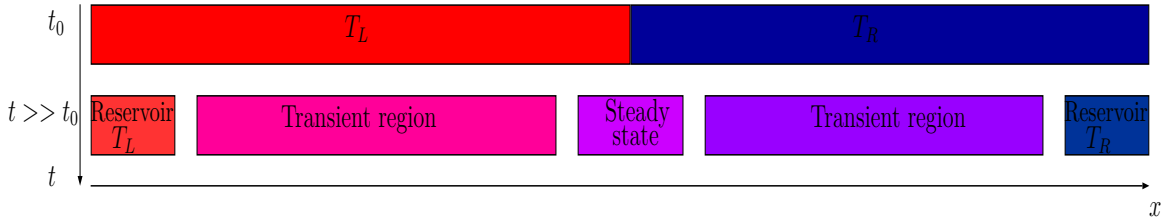

Figure 1.1: At very large time the system will be divided in different regions. At infinities there will be the asymptotic reservoirs which have not still receive excitations from the connections point, near the connection point the system will reach the steady state which is separated from reservoirs by two transient regions.

These two halves are independently thermalized at two different temperatures  $T_l = 1/\beta_l$  and  $T_r = 1/\beta_r$ . At time  $t_0$  the two systems are coupled together and form the total system (1.2)

$$H = H_l + H_r + \delta H \quad (1.4)$$

where  $\delta H$  represent the interaction between the two halves. The density matrix of this systems, at time  $t_0$ , is:

$$\rho_0 = e^{-\beta_l H_l + \beta_r H_r} / Z, \quad (1.5)$$

and the vacuum expectation value of a local observable at time  $t_0$  reads

$$\langle \mathcal{O} \rangle = \text{Tr}_{\mathcal{H}}[\rho_0 \mathcal{O}]. \quad (1.6)$$

The average of observables at times  $t > t_0$  has to be taken with time-evolved states and is given by

$$\langle \mathcal{O} \rangle_t = \text{Tr}_{\mathcal{H}}[\rho(t) \mathcal{O}] = \text{Tr}_{\mathcal{H}}[\rho \mathcal{O}(t)], \quad \mathcal{O}(t) = e^{-itH} \mathcal{O} e^{itH}. \quad (1.7)$$

Finally, the third step correspond to take the limit for the very large time and for the very large space, as in equation (1.1).

## 1.2 Hydrodynamics approach

Non-homogeneous systems can be described by the very recent method named “hydrodynamics approach” [5, 6, 7, 8, 9, 10, 11, 12], which makes use of the ideas of classical hydrodynamics. The emergence of hydrodynamics in many-body systems is based on the assumption of local entropy maximization (or local thermodynamic equilibrium). This assumption states that, at large times, and in large space, the system decomposes into “fluid cells”. All physical quantities vary slowly between adjacent cells and all cells are in equilibrium, where homogeneous Gibbs states exist. This means that we are observing the system on the length scale of the distributions (or clouds) of particles instead of the length scale of the single particles (see Figure 1.2).

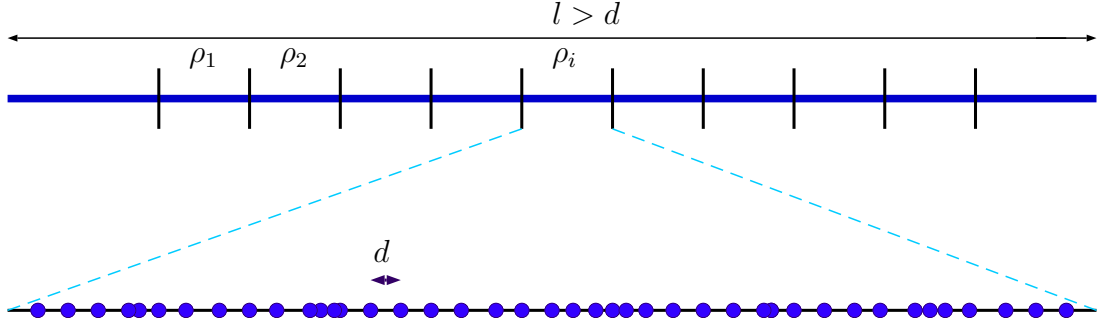

Figure 1.2: Representation of (1 + 1)-D quantum system. In the bottom, the dominating length scale is given by the average distance between particles, and on the top, it is represented the hydrodynamic zoomed-out picture of the system. In the hydrodynamic approximation each fluid cell is in local equilibrium and the density matrix varies between neighboring cells.

The basic ingredients of hydrodynamic approach of many-body extended systems are the local conserved quantities in involution  $Q_i$ ,  $i \in \{1, 2, \dots, N\}$ . These are integrals of local densities  $q_i(x, t)$  which satisfy the continuity relations (or conservation laws),

$$\partial_t q_i(x, t) + \partial_x j_i(x, t) = 0, \quad (1.8)$$

where  $j_i$  are the associated local currents. These equations appear as a consequence of the total charges  $Q_i := \int dx q_i(x, t)$  being conserved  $\partial_t Q_i = 0$ . The averages of local densities are given by

$$\mathbf{q}_i := \langle q_i \rangle_{\underline{\beta}}, \quad \mathbf{j}_i := \langle j_i \rangle_{\underline{\beta}} \quad (1.9)$$

and they are described by the following density matrix:

$$\rho = \frac{\exp(-\sum_i \beta_i Q_i)}{\text{Tr}[\exp(-\sum_i \beta_i Q_i)]} \quad (1.10)$$

where  $\beta_i$  are the associated potentials, and the subscription  $\underline{\beta}$  indicate the vector of them. The assumption of the hydrodynamic formulation imply that the many-body systems relax or “equilibrate” on each fluid cell where the Gibbs states are reached. The density matrix becomes space-time coordinates dependent, in particular, there is an explicit dependence in thermodynamic potentials:

$$\rho(x, t) = \frac{\exp(-\sum_i \beta_i(x, t) Q_i)}{\text{Tr}[\exp(-\sum_i \beta_i(x, t) Q_i)]}. \quad (1.11)$$

So, in hydrodynamic approximation, averages of the local observables, at large time, tend to averages evaluated in local Gibbs ensemble:

$$\langle \mathcal{O}(x, t) \rangle \approx \langle \mathcal{O} \rangle_{\beta(x, t)} = \text{Tr}[\rho(x, t) \mathcal{O}] \quad (1.12)$$

and the local densities of charges and currents, in this approximation, become:

$$\langle q_i(x, t) \rangle \approx \langle q_i \rangle_{\beta(x, t)} = \underline{\mathbf{q}}(x, t) \quad \langle j_i(x, t) \rangle \approx \langle j_i \rangle_{\beta(x, t)} = \underline{\mathbf{j}}(x, t). \quad (1.13)$$

The conservation equations for microscopic particles (1.8) can be rewritten in the form involving macroscopic quantities:

$$\partial_t \underline{\mathbf{q}}(x, t) + \partial_x \underline{\mathbf{j}}(x, t) = 0. \quad (1.14)$$

These are hydrodynamics (Euler) equations, which represent the quantum dynamics of conserved densities. Between expectation values of conserved densities and local currents there exist functional relations of the form:

$$\underline{\mathbf{j}} = \mathcal{F}(\underline{\mathbf{q}}). \quad (1.15)$$

These are equations of state (EOS), model dependent, relations. EOS putted into the conservation equations (1.14) give

$$\partial_t \underline{\mathbf{q}}(x, t) + \partial_x (\mathcal{F}(\underline{\mathbf{q}}(x, t))) = 0 \quad (1.16)$$

or

$$\partial_t \underline{\mathbf{q}}(x, t) + \mathbf{J}(\underline{\mathbf{q}}) \partial_x \underline{\mathbf{q}}(x, t) = 0 \quad (1.17)$$

where  $J_{ij}$  is the Jacobian  $N \times N$  matrix defined as:

$$J_{ij} = \frac{\partial \mathcal{F}_i(\underline{\mathbf{q}})}{\partial \mathbf{q}_j}. \quad (1.18)$$

The Jacobian can be diagonalized with some change of coordinates of states  $\underline{\mathbf{q}} \rightarrow \underline{\mathbf{n}}$ . In these new coordinates it reads

$$\partial_t \underline{\mathbf{n}}_i(x, t) + v_i^{eff}(\underline{\mathbf{n}}(x, t)) \partial_x \underline{\mathbf{n}}_i(x, t) = 0. \quad (1.19)$$

The eigenvalues of Jacobian  $v^{eff}$  can be interpreted like propagation velocities of normal modes. Since equation (1.19) is invariant under the rescaling  $(x, t) \rightarrow (ax, at)$ , we can take the limit  $a \rightarrow \infty$ . So, we are looking for a self-similar solutions where the quantities depend on the ray  $\xi = x/t$ , instead of the space-time coordinates. The partial derivatives should be recast as follows:

$$\frac{\partial}{\partial x} = \frac{1}{t} \frac{\partial}{\partial \xi}, \quad \frac{\partial}{\partial t} = -\frac{1}{t} \xi \frac{\partial}{\partial \xi}. \quad (1.20)$$

The relation (1.17) becomes eigenvalue equation,

$$(\mathbf{J}(\underline{\mathbf{q}}) - \xi) \partial_\xi \underline{\mathbf{q}} = 0. \quad (1.21)$$

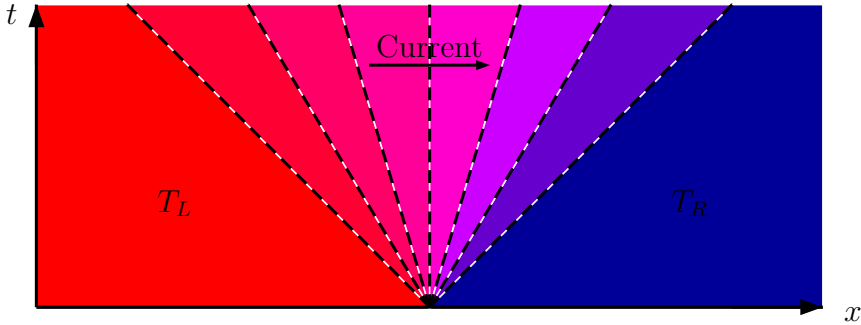

Figure 1.3: Representation of the partitioning protocol. Dotted lines show different values of “ray”  $\xi = x/t$ . The steady states lie on the ray  $\xi = 0$ .

At this point, we expect that asymptotically, for large  $x$  ( $x \rightarrow \pm\infty$ ), the solutions of these equations are compatible with the original systems in thermal equilibrium with the heat baths. In ray coordinates this condition is implemented taking the limit  $\xi \rightarrow \pm\infty$ ,

$$\lim_{\xi \rightarrow \pm\infty} \underline{\mathbf{q}}(\xi) = \lim_{x \rightarrow \pm\infty} \langle \underline{q}(x, 0) \rangle_{ini}. \quad (1.22)$$

The steady state averages are defined as

$$\underline{\mathbf{q}}^{sta} := \underline{\mathbf{q}}(\xi = 0), \quad \underline{\mathbf{j}}^{sta} := \underline{\mathbf{j}}(\xi = 0). \quad (1.23)$$

Solutions to the equations (1.21), which satisfy the condition given by (1.23), fully characterize the large time and large space limit system along the ray  $\xi$ .

### 1.3 Generalized Gibbs ensemble and Generalized Hydrodynamics

Generically, the relaxation of some non-equilibrium system is closely related to the conserved quantities of the system. The thermalization of closed non-integrable quantum systems is described in [A](#). In integrable systems, with an infinite number of conserved charges, it is broadly believed that the stationary state, in long time limit, is described by the Generalized Gibbs Ensemble (GGE) [[13](#), [14](#), [15](#), [16](#)]. The steady state reached by the system can be described by the density matrix,  $\rho_{GGE}$ ,

$$\rho_{GGE} = \frac{1}{\text{Tr}[\rho_{GGE}]} e^{-\sum_{i=1}^{\infty} \beta_i Q_i}. \quad (1.24)$$

The set of conserved charges must be defined very carefully. In fact, we have to consider also quasi-local densities and currents which are involved in thermalization. These quantities have a support on an extended region of the systems domain, with generically an exponentially decaying norm.

For instance, in Heisenberg spin chain model, we can define

- local operators

$$\mathcal{O}_{loc} = \sum_i s_i s_{i+1}. \quad (1.25)$$

- non local operators

$$\mathcal{O}_{nloc} = \sum_i s_i s_{i+1} + s_i s_{i+2} + s_i s_{i+3} + \dots \quad (1.26)$$

- quasi local operators

$$\mathcal{O}_{qloc} = \sum_i s_i s_{i+1} + e^{-1} s_i s_{i+1} + e^{-2} s_i s_{i+1} + \dots \quad (1.27)$$

In the most of cases the quasi-local charges are defined to have an exponential decay.

The demonstration of the relevance of finitely many conserved charges in 1d non-equilibrium systems come from the pioneering experiment ‘‘Quantum Newton Cradle’’ [17]. This experiment consisted in preparation of out-of-equilibrium trapped 1d Bose gas. It was observed that after a long time the gas did not thermalize but two oscillating clouds of gas emerged. It represents a failure of the standard Gibbs ensemble to describe an integrable system. In [18] the hydrodynamic description of Quantum Newton Cradle experiment was proposed.

In the hydrodynamic description of integrable systems we have to consider all conserved charges. So, there will be an infinite number of conservation equations

$$\partial_t \underline{q}_i + \partial_x \underline{j}_i = 0, \quad i = 1, 2, 3, \dots \quad (1.28)$$

where

$$\underline{q}_i = \frac{\text{Tr}[\rho_{GGE}(x, t) q_i]}{\text{Tr}[\rho_{GGE}(x, t)]}, \quad \underline{j}_i = \frac{\text{Tr}[\rho_{GGE}(x, t) j_i]}{\text{Tr}[\rho_{GGE}(x, t)]}, \quad i = 1, 2, 3, \dots \quad (1.29)$$

These equations, with the equations of state, represent the Generalized Hydrodynamics description of non-equilibrium integrable systems.

## 1.4 Conventional hydrodynamics

The previously introduced continuity equations can be rewritten in the conventional hydrodynamic equation. Generically, in GGE, the density associated to the derivative of energy is equal to the current of the derivative of momenta

$$j[p'] = q[E']. \quad (1.30)$$

In relativistic (1+1)-D systems we have that

$$E'(\theta) = p(\theta), \quad p'(\theta) = E(\theta). \quad (1.31)$$

We define the fluid velocity of the energy current as

$$v := \frac{j[p']}{q[p']}. \quad (1.32)$$

Now, consider conservation equations for energy density and momentum density

$$\partial_t q[p'] + \partial_x j[p'] = 0 \quad (1.33)$$

$$\partial_t q[E'] + \partial_x j[E'] = 0. \quad (1.34)$$

By putting (1.31) and (1.32) into (1.33) and (1.34) the following equation holds

$$\partial_x j[E'] - \partial_x(v^2 \rho) + \rho \partial_t v + v \rho \partial_x v = 0. \quad (1.35)$$

Now, if we define energy density and pressure to be

$$\rho_{fl} := q[p'], \quad \mathcal{P} := j[E'] - \rho_{fl} v^2 \quad (1.36)$$

it leads to the classical Euler equation

$$\partial_t v + v \partial_x v = -\frac{1}{\rho_{fl}} \partial_x \mathcal{P}. \quad (1.37)$$

This is the equation for velocity that describes a fluid in absence of viscosity. The generalization of this formula is represented by the Navier-Stokes equation

$$\partial_t v + v \partial_x v = -\frac{1}{\rho_{fl}} \partial_x \mathcal{P} + \xi \frac{1}{\rho_{fl}} \partial_x^2 v, \quad (1.38)$$

where  $\xi$  is the viscosity term. This relation can be employed in GHD formulation in order to describe systems coupled to external potentials or dissipative systems.

## CHAPTER 2

---

### Integrability

---

The strategy, adopted in this thesis, to study the  $(1 + 1)$ -D quantum non-equilibrium systems is based on the combination of ideas of hydrodynamics and the standard integrability techniques. In this chapter we will briefly present some integrability tools used to solve  $(1+1)$ -D integrable systems. We will start by describing general properties of S-matrix theory. This theory can be thought of as an alternative to the standard QFT approach. The S-matrix is the fundamental ingredient of the Thermodynamic Bethe Ansatz used to recast the GHD in quasi-particle language.

We will quickly recall some basic concepts of *Conformal Field Theory (CFT)*, essential to the formulation of Perturbed conformal field theory. So, we will show how to construct models defined as a deviation of conformal models from their fixed point. This deviation is obtained by perturbing the conformal model with some primary operator. Not all perturbed theories are integrable, we will study the method used to establish if a theory is integrable or not.

### 2.1 S-Matrix theory

The S-matrix theory [19, 20, 21, 22] represents a non-perturbative approach for the calculation of scattering processes in QFT, without the use of a Lagrangian formulation. The S-matrix approach is a self-consistent dynamical method based on few concepts, among which:

- unitarity;
- Lorentz invariance;



- macrocausality;
- analyticity;
- crossing symmetry.

In the (1+1)-D integrable theories, the existence of higher spin conserved quantities, implies

- no particle production in the scattering process;
- the conservation of the momenta of singular particles in the scattering process;
- factorization of any scattering process into a product of two-particle scattering.

The S-matrices satisfy the following fundamental equations

- Yang-Baxter equations;
- bootstrap equations.

In order to adopt the S-matrix formalism we assume that the interactions are of the short range type and involve very small region. Initial and final states particles are well separated and can be considered free. The scattering process involves only the physical particles, so the momenta satisfy the on-shell condition

$$p_\mu p^\mu = m^2. \quad (2.1)$$

Formally, we define the asymptotic state

$$|p_1, p_2, \dots, p_n\rangle^{in/out}, \quad (2.2)$$

where  $n$  is the number of particles, *in* corresponds to initial state at  $t = -\infty$ , and *out* corresponds to final state at  $t = +\infty$ . For brevity, we will use the notation  $|i\rangle$  to denote the initial state and  $|f\rangle$  to denote the final state. The S-matrix is the unitary operator  $S$  that determines the evolution of the initial state to the final state

$$|f\rangle = S |i\rangle. \quad (2.3)$$

This relation defines an isomorphism between two Hilbert spaces. It maps the final state into the initial one or vice versa. The asymptotic states form a complete basis of the Hilbert space and satisfy the orthogonality and completeness relations

$$\langle m|n\rangle = \delta_{mn}, \quad \sum_n |n\rangle \langle n| = 1. \quad (2.4)$$

Now, we consider an initial state expressed as superposition of the basis vectors

$$|\psi\rangle = \sum_n a_n |n\rangle \quad (2.5)$$

where  $\sum_n |a_n|^2 = 1$ . The total probability conservation leads to the following equation

$$1 = \sum_m |\langle m|S|\psi\rangle|^2 = \sum_m \langle\psi|S^\dagger S|\psi\rangle = \sum_{n,m} a_n^* a_m \langle n|S^\dagger S|n\rangle \quad (2.6)$$

which implies S-matrix to be unitary

$$SS^\dagger = 1. \quad (2.7)$$

Next, we analyze the *Lorentz invariance* of the scattering theory. If some proper Lorentz transformation  $L$  acts on some vector like  $L|m\rangle = |m'\rangle$  we require

$$\langle m'|S|n'\rangle = \langle m|S|n\rangle. \quad (2.8)$$

This equation implies that the S-Matrix elements depend on Lorentz-invariant combination of momenta. For instance, the two-body scattering process of two spinless particles, with initial momenta  $p_1$  and  $p_2$  which are going into two spinless particles with momenta  $p_3$  and  $p_4$ , can be expressed in term of the *Maldestram variables*  $s, t$ , and  $u$ , where

$$s = (p_1 + p_2)^2, \quad t = (p_1 - p_3)^2, \quad u = (p_1 - p_4)^2. \quad (2.9)$$

The total energy-momentum conservation and the mass-shell condition introduce a constraint on these quantities. Hence, from

$$p_1 + p_2 = p_3 + p_4, \quad p_i^2 = m_i^2 \quad (i = 1, 2, 3, 4) \quad (2.10)$$

it follows that

$$s + t + u = \sum_i^4 m_i^2. \quad (2.11)$$

The meaning of these variables is easy to understand, for example,  $s$  in the reference frame of the center of mass ( $\vec{p}_1 + \vec{p}_2 = 0$ ) is the square of the total energy ( $E = E_1 + E_2$ ). Similarly,  $t$  represents the total square energy in the center of mass of the crossed channel

$$A_1 + \bar{A}_3 \rightarrow \bar{A}_2 + A_4 \quad (2.12)$$

and  $u$  has the same meaning for the reaction

$$A_1 + \bar{A}_4 \rightarrow \bar{A}_2 + A_3. \quad (2.13)$$

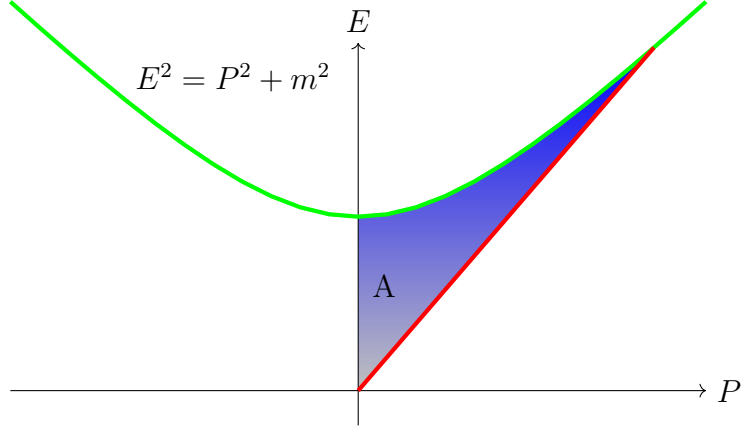

Figure 2.1: The area delimited by the hyperbola (dispersion relation) and the straight line joining the origin and the point on the hyperbola parametrized by the rapidity  $\theta$  is given by the law  $A = \frac{\theta m^2}{2}$ .

### 2.1.1 S-matrix in (1+1)-dimensions

In (1 + 1)-dimensions we can parametrize the momenta in term of *rapidity variables*

$$p_i^0 = E_i = m_i \cosh \theta_i, \quad p_i^1 = P_i = m_i \sinh \theta_i \quad (2.14)$$

where  $m_i$  is the mass of the particle  $i$ . This parametrization satisfies the dispersion relation  $E_i^2 - P_i^2 = m_i^2$ . In fig.2.1 is represented a geometrical interpretation of the rapidity variables. The light-cone momenta are defined as

$$p_i = p_i^0 + p_i^1 = m_i e^{\theta_i}, \quad \bar{p}_i = p_i^0 - p_i^1 = m_i e^{-\theta_i} \quad (2.15)$$

and satisfy the mass-shell condition

$$p_i \bar{p}_i = m_i^2. \quad (2.16)$$

The rapidity difference between two particles  $\theta_{AB} := \theta_A - \theta_b$  is a Lorentz invariant. The Lorentz invariance nature of S-matrices implies that these matrices must depend only on the rapidity difference of scattering particles. In order to study the algebraic properties of the S-matrix, let us introduce the vertex operators  $V_a(\theta_a)$ , which may be of bosonic or fermionic type, and represent the asymptotic particle of rapidity  $\theta_a$ . The S-matrix elements satisfy a set of relations which forms the *Faddeev-Zamolodchikov*

algebra:

$$V_a(\theta_1)V_b(\theta_2) = \sum_{cd} S_{ab}^{cd}(\theta_{12})V_d(\theta_2)V_c(\theta_1) \quad (2.17)$$

$$V_a^\dagger(\theta_1)V_b^\dagger(\theta_2) = \sum_{cd} S_{ab}^{cd}(\theta_{12})V_d^\dagger(\theta_2)V_c^\dagger(\theta_1) \quad (2.18)$$

$$V_a(\theta_1)V_b^\dagger(\theta_2) = \sum_{cd} S_{ab}^{cd}(-\theta_{12})V_d(\theta_2)V_c(\theta_1) + 2\pi\delta_{ab}\delta(\theta_{12}). \quad (2.19)$$

The vertex operator can be used to construct the space of physical states. The vacuum state is defined by

$$V_a(\theta)|0\rangle = 0 = \langle 0|V_a^\dagger(\theta) \quad (2.20)$$

where  $V_a^\dagger(\theta)/V_a(\theta)$  is the creation/annihilation operators, the Hilbert space is obtained by repeated action of creation operators on the ground state

$$|V_{a_1}(\theta), V_{a_2}(\theta), \dots, V_{a_N}(\theta)\rangle = V_{a_1}^\dagger(\theta)V_{a_2}^\dagger(\theta), \dots, V_{a_N}(\theta)^\dagger|0\rangle. \quad (2.21)$$

The 2-body scattering amplitudes can be written as

$$S_{ab}^{cd}(\theta_a = \theta_c, \theta_b = \theta_d) := {}_{out}\langle V_c(\theta_1)V_d(\theta_2)|V_a(\theta_1)V_b(\theta_b)\rangle_{in} = S_{ab}^{cd}(\theta_{12}). \quad (2.22)$$

The linear combination of the states (2.21) generates the Hilbert space. These states are not all independent, so some selection prescription must be introduced. Such prescription can be defined as the ordering requirement, namely for in-state the rapidities must be ordered from the left to the right

$$|V_{a_1}(\theta_1), V_{a_2}(\theta_2), \dots, V_{a_N}(\theta_N)\rangle_{in}, \quad \text{with } \theta_1 > \theta_2 > \dots > \theta_N \quad (2.23)$$

and for the out-state the ordering is defined in the opposite direction

$$|V_{a_1}(\theta_1), V_{a_2}(\theta_2), \dots, V_{a_N}(\theta_N)\rangle_{out}, \quad \text{with } \theta_1 < \theta_2 < \dots < \theta_N. \quad (2.24)$$

These prescriptions mean that the particles in in/out-states do not interact in the limit  $t \rightarrow \mp\infty$ .

The existence of an infinite number of commuting conserved charges  $Q_i$  is the fundamental requirement for a QFT to be integrable. Consider the application of the momenta (spin-one operator), in the light-cone components (2.15), on the one-particle state

$$P|V_a(\theta)\rangle = m_a e^\theta |V_a(\theta)\rangle, \quad \bar{P}|V_a(\theta)\rangle = m_a e^{-\theta} |V_a(\theta)\rangle. \quad (2.25)$$

In the higher representation of the (1 + 1)-dimensional Lorentz group, these conserved charges can be also simultaneously diagonalized in the basis (2.21), and the one-particle eigenstate reads,

$$Q_s|V_a(\theta)\rangle = \omega_a^s(m_a e^\theta)^s |V_a(\theta)\rangle, \quad (2.26)$$

the  $n$ -particle version is given by

$$Q_s |V_{a_1}(\theta_1), V_{a_2}(\theta_2), \dots, V_{a_n}(\theta_n)\rangle = \sum_i \omega_{a_i}^s (m_{a_i} e^{\theta_i})^s |V_{a_1}(\theta_1), V_{a_2}(\theta_2), \dots, V_{a_n}(\theta_n)\rangle \quad (2.27)$$

where  $\omega_a^s$  is the eigenvalue of the charge  $Q_s$  of the particle  $a$ . The quantity  $Q_{|s|}$  transforms as  $s$  copies of  $P$  and  $Q_{-|s|}$  as  $s$  copies of  $\bar{P}$ , where the integer  $s$  is the Lorentz spin.

Now we are able to demonstrate the absence of particle production in the  $(1+1)$ -D integrable systems. For this purpose, consider a scattering process of  $n$  in-states and  $p$  out-states, described by the scattering element

$$S_{a_1 a_2 \dots a_p}^{b_1 b_2 \dots b_n} =_{out} \langle V_{b_1}(\theta_{b_1}), V_{b_2}(\theta_{b_2}), \dots, V_{b_n}(\theta_{b_n}) | V_{a_1}(\theta_{a_1}), V_{a_2}(\theta_{a_2}), \dots, V_{a_p}(\theta_{a_p}) \rangle_{in} \quad (2.28)$$

The conserved charge satisfying (2.27), must remain conserved in the scattering process (2.28), namely

$$\sum_{i=1}^p \omega_{a_i}^s (m_{a_i} e^{\theta_i})^s = \sum_{i=1}^n \omega_{b_i}^s (m_{b_i} e^{\theta'_i})^s. \quad (2.29)$$

In the integrable theories there are an infinite number of conserved charges, the equation (2.29) is a system of infinitely many non linear equations. The unique solution of such system is given by

$$\theta_i = \theta'_i, \quad p = n. \quad (2.30)$$

or  $\omega_{a_i}^s = \omega_{b_i}^s$ ,  $i = 1, 2, \dots, n$ . This solution means that the number of particles remain the same before and after the scattering process and the initial and final sets of momenta are equal. This is the case of *elastic scattering*.

## 2.1.2 Factorization and Yang-Baxter equation

Another consequence of the existence of an infinite number of conserved charges, in the scattering process, is the *factorizability*. By factorizability we mean that a  $n$ -particles scattering process can be expressed in terms of 2-particles collisions. This statement has been proved by S. J. Parke in [23]. The demonstration is based on the effect of the conserved charges  $Q_s$  on the localized wavepacket. Consider the wavefunction describing the one-particle state

$$\psi(x) \propto \int_{-\infty}^{\infty} dp e^{-a^2(p-p_1)} e^{ip(x-x_1)}. \quad (2.31)$$

This represent a particle localized in momentum space around  $(p = p_1)$  and in coordinate space around  $(x = x_1)$ . The action in this state with an operator  $e^{icQ_s}$ , where  $c$  is a constant and  $Q_s$  is a conserved charge, is given by

$$\tilde{\psi}(x) \propto \int_{-\infty}^{\infty} dp e^{-a^2(p-p_1)} e^{ip(x-x_1)} e^{icp^s}, \quad (2.32)$$

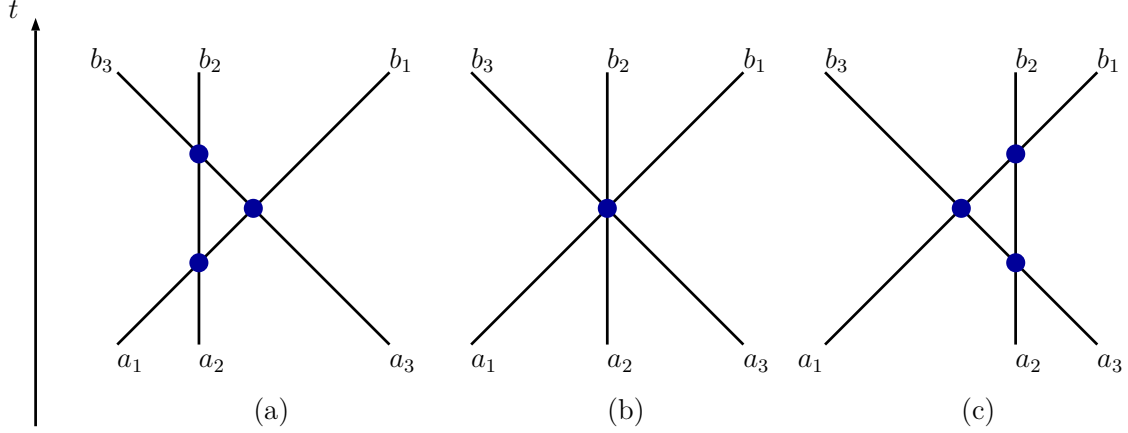

Figure 2.2: Representation of possible combination of scattering of the three particles. In (c) the scattering of the three particles is simultaneous and in (a) and (b) the scattering is made by two-particle collisions.

since  $e^{icQ_s} |p\rangle = e^{icp^s} |p\rangle$ . This function is localized near the new position  $x = x_1 - scp_1^{s-1}$ . In the case  $s = 1$ , the total momenta, the wavepackets will be shifted by the amount  $c$ . The fundamental point comes out in the case  $s > 1$ , the particles with different momenta are translated by different amounts.

In order to understand the factorizability, consider the process of collision of three particles with momenta ordered as  $p_1 < p_2 < p_3$ . This scattering may happen in three different ways, as illustrated in (fig.2.2). In a generic QFT these three processes have different amplitudes. In the presence of higher conserved charges, we can write a three-particle amplitude as

$$\begin{aligned} & \langle V_{b_1}(\theta_{b_1}), V_{b_2}(\theta_{b_2}), V_{b_3}(\theta_{b_3}) | S | V_{a_1}(\theta_{a_1}), V_{a_2}(\theta_{a_2}), V_{a_3}(\theta_{a_3}) \rangle \\ & = \langle V_{b_1}(\theta_{b_1}), V_{b_2}(\theta_{b_2}), V_{b_3}(\theta_{b_3}) | e^{icP_s} S e^{-icP_s} | V_{a_1}(\theta_{a_1}), V_{a_2}(\theta_{a_2}), V_{a_3}(\theta_{a_3}) \rangle, \end{aligned} \quad (2.33)$$

since conserved charges commute with S-matrix. So, the three amplitudes can be transformed into each other, leaving invariant the scattering amplitude, by acting with the conserved charges.

The equivalence between collisions represented in (fig.2.2) leads to the *Yang-Baxter equation* (YBE) which can be written as

$$S_{a_1 a_2}^{ij}(\theta_{12}) S_{i a_3}^{b_1 k}(\theta_{13}) S_{j k}^{b_2 b_3}(\theta_{23}) = S_{a_1 i}^{k b_3}(\theta_{13}) S_{a_2 a_3}^{j i}(\theta_{23}) S_{k i}^{b_1 b_2}(\theta_{12}). \quad (2.34)$$

This factorization property also holds for the  $n \rightarrow n$  scattering, which can be factorized in  $n(n-1)/2$  of  $2 \rightarrow 2$  S-matrices.

The diagonal S-matrices are generally easy to construct, and they can be represented as

$$S_{cd}^{ab}(\theta_{12}) = \delta_c^a \delta_d^b S_{cd}(\theta_{12}). \quad (2.35)$$

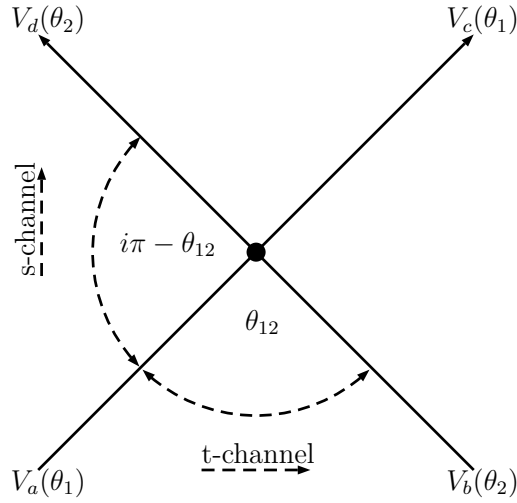

Figure 2.3: The graphical representation of elements of the two-particle S-matrix  $S_{ab}^{dc}(\theta_{12})$ .

In this case the Yang-Baxter equation (2.34) is trivially satisfied. The diagonal S-matrices have also the property of the conservation of quantum numbers in the scattering process.

### 2.1.3 Two-particle S-matrix

Any n-particle scattering in the integrable theories can be determined by the two-particle S-matrices. Therefore, the description of the properties of two-particle S-matrix becomes of fundamental importance.

In the algebraic notation, developed in the previous sections, the two-particle S-matrix elements read

$$|V_a(\theta_1), V_b(\theta_2)\rangle_{ini} = S_{ab}^{cd}(\theta_{12}) |V_c(\theta_1), V_d(\theta_2)\rangle_{out} \quad (2.36)$$

where  $\theta_1 > \theta_2$ . It turns out that the two-particle S-matrix depends only on the one Mandelstam variable  $s$  because  $u = 0$  and  $t(\theta_{12}) = s(i\pi - \theta_{12})$ .

**Discrete symmetries.** The S-matrix is invariant for C, P, and T transformations, there are the following relations

- *charge conjugation:*

$$S_{ab}^{cd}(\theta) = S_{\bar{a}\bar{b}}^{\bar{c}\bar{d}}(\theta), \quad (2.37)$$

- *parity:*

$$S_{ab}^{cd}(\theta) = S_{ba}^{dc}(\theta), \quad (2.38)$$

- *time reversal:*

$$S_{ab}^{cd}(\theta) = S_{dc}^{ba}(\theta). \quad (2.39)$$

**Unitary and Crossing symmetry.** As discussed previously, the S-matrix has to satisfy the unitarity condition  $SS^\dagger = S^\dagger S = 1$ . This constraint means that the probability to produce an *out*-state from an *in*-state is 1. The unitarity condition can be expressed as

$$\sum_{cd} S_{ab}^{cd}(\theta) S_{cd}^{ef}(-\theta) = \delta_a^e \delta_b^f. \quad (2.40)$$

The crossing symmetry means that the two-particle amplitude must remain invariant when one of the incoming particles and one of the outgoing particles are interchanged.

$$S_{ab}^{cd}(\theta) = S_{\bar{a}\bar{d}}^{\bar{c}\bar{b}}(i\pi - \theta) \quad (2.41)$$

This property also explains the mutual dependence between  $s$  and  $t$  channels.

**Analyticity.** The analyticity properties of the S-matrix are generically studied in terms of Mandelstam variables  $s$ ,  $t$  and  $u$ . Using the first equation of the (2.9), we can write the  $s$  variable using the rapidity difference, namely

$$s = m_a^2 + m_b^2 + 2m_a m_b \cosh \theta_{12}. \quad (2.42)$$

$\theta_{12}$  has to be real for a physical process. Consequently,  $s$  has to be real. We can analytically continue the variables  $s$  and  $\theta_{12}$  to the complex plane. This implies that the  $s$ -plane will have two branch points at  $s = (m_a \pm m_b)^2$ , where the two branch cuts defined as  $s \geq (m_a + m_b)^2$  and  $s \leq (m_a - m_b)^2$  start. Let us define the *physical region* with  $s^+ = s + i0$  and  $s > (m_a + m_b)^2$ .

Imposing the unitarity condition for the physical sheet, we obtain

$$S_{ab}^{cd}(s^+) (S_{dc}^{ef}(s^+))^* = \delta_a^e \delta_b^f. \quad (2.43)$$

The analyticity assumption allows to recast the unitarity property into the hermitian analyticity

$$S_{ab}^{cd}(s^*) = (S_{cd}^{ab})^*(s) \quad (2.44)$$

and using the time reversal symmetry, we can write the *real analyticity property*, namely

$$S_{ab}^{cd}(s^*) = (S_{ab}^{cd})^*(s). \quad (2.45)$$

This equation implies that  $S(s)$  is real whether  $s$  is itself real and  $(m_a - m_b)^2 \leq s \leq (m_a + m_b)^2$ . Therefore, to real S-matrices do not correspond physical processes.

Call  $S_\gamma$  the S-matrix obtained by the analytic continuation below the cut around the branch point in  $s = (m_a + m_b)^2$ . Imposing the unitarity condition, we obtain

$$S_\gamma(s^+) = S^{-1}(s^+), \quad (2.46)$$

if we call  $s^- = s - i0$ , the point below the cut, we have

$$S_\gamma(s^-) = S^{-1}(s^-) = S(s^+). \quad (2.47)$$



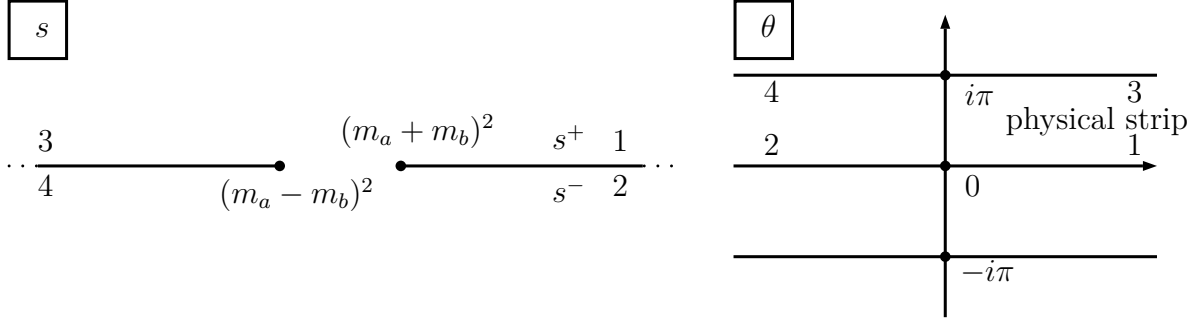

Figure 2.4: Complex  $s$ -plane and  $\theta$ -plane.

The last equality is the consequence of application of unitarity twice. It follows that the branch point is a square root singularity because a double rotation around the branch point  $s = (m_a + m_b)^2$  gets us back to the starting point.

Let us call  $\theta := \theta_{12}$ , the difference between rapidities. We can study the plane generated by this variable by inverting the relation (2.42)

$$\begin{aligned} \theta &= \text{arccosh}\left(\frac{s - m_a^2 - m_b^2}{2m_a m_b}\right) \\ &= \log\left(\frac{s - m_a^2 - m_b^2 + \sqrt{(s - (m_a + m_b)^2)(s - (m_a - m_b)^2)}}{2m_a m_b}\right). \end{aligned} \quad (2.48)$$

It comes out that the physical region in the  $\theta$ -plane is in the strip  $0 \leq \text{Im}\theta \leq \pi$  where the cuts are opened in the positions  $0$  and  $i\pi$ . The others sheets are mapped periodically on the strips

$$n\pi \leq \text{Im}\theta \leq (n+1)\pi, \quad n = \dots, -2, -1, 0, 1, 2, \dots, \quad (2.49)$$

with branch points at  $\theta = i\pi n$ . So, the integrability imply that  $S(\theta)$  is a meromorphic function and it is real on the imaginary axis of  $\theta$ .

**Bootstrap equations.** The properties described so far do not provide any information about the particles content of the S-matrix. The bound states of the theory generally correspond to simple poles in the physical strip. Consider a S-matrix with a simple pole in  $\theta = iu_{ab}^p$ . Therefore, the corresponding amplitude is described by the S-matrix expressed as

$$S_{ab}^{cd}(\theta) \simeq i \frac{\Gamma_{ab}^p R^p \Gamma_p^{cd}}{\theta - iu_{ab}^p} \quad (2.50)$$

where  $R^p$  is the residue and the functions  $\Gamma_{ab}^p$  and  $\Gamma_p^{cd}$  are the projectors of single particle space onto the bound state space.

From the definition of the Mandelstam variable  $s$ , the mass of the bound state is given by

$$m_c^2 = m_a^2 + m_b^2 + 2m_a m_b \cos u_{ab}^c. \quad (2.51)$$

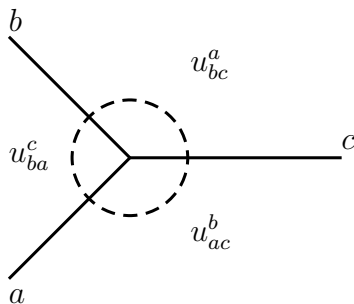

Figure 2.5: Relations between the positions of the poles.

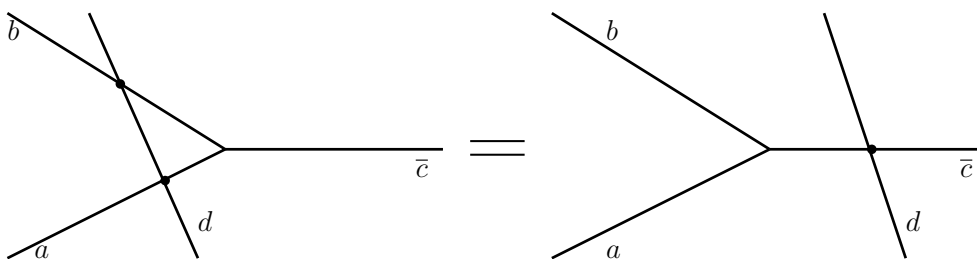

Figure 2.6: Representation of the bootstrap principle.

The quantity  $u_{ab}^c$  is called *fusing angle* and it is related to the geometrical property given by the Carnot theorem, as in (fig.2.5). The three fusing angles satisfy the relation

$$u_{ba}^c + u_{bc}^a + u_{ac}^b = 2\pi \quad (2.52)$$

which reflects that any of the particles  $a$ ,  $b$  and  $c$  can be seen as the bound state of other two.

The previously described ideas do not allow to fix the positions of the poles of the amplitudes. With this purpose the *bootstrap principle* was formulated. It states that the bound states are considered at the same footing as fundamental particles and the processes in the (fig.2.6) must coincide. For the diagonal S-matrices (2.35), the equivalence between these two processes leads to the *bootstrap equations*

$$S_{\bar{c}d}(\theta) = S_{ad}(\theta + i\bar{u}_{ac}^b)S_{bd}(\theta - i\bar{u}_{bc}^a), \quad (2.53)$$

with  $\bar{u} = \pi - u$ . The bootstrap principle gives a powerful tool to derive the particle content of the theory.

## 2.2 Conformal Field Theory: a brief overview

In this section we briefly summarize some of the most important points of 2-dimensional Conformal Field Theory (CFT). Deeper understanding of CFT arguments may be achieved by reading [22, 40].

The CFT is a Quantum Field Theory, which is invariant under the conformal group. In particular, consider the  $d$ -dimensional metric tensor  $g_{\mu\nu}$  with signature  $(-, +, +, \dots)$ . The conformal transformation is defined as the invertible coordinates mapping which leaves invariant the metric tensor under scaling:

$$g_{\mu\nu}(x') = \Lambda(x)g_{\mu\nu}(x), \quad (2.54)$$

where  $\Lambda(x)$  is an arbitrary smooth scalar function of the coordinates. The conformal group contains the Poincaré group, which corresponds to the special case  $\Lambda(x) = 1$ . The infinitesimal form of the conformal transformation is given by

$$x^\mu \rightarrow x'^\mu = x^\mu + \epsilon^\mu(x), \quad |\epsilon(x)| \ll 1, \quad (2.55)$$

under such transformation, the metric, at first order become

$$g_{\mu\nu} \rightarrow g_{\mu\nu} + (\partial_\mu \epsilon_\nu(x) + \partial_\nu \epsilon_\mu(x)). \quad (2.56)$$

The following relations hold in the case of conformal transformations:

$$\partial_\mu \epsilon_\nu(x) + \partial_\nu \epsilon_\mu(x) = f(x)g_{\mu\nu}, \quad (2.57)$$

where  $f(x)$  is some function which can be determined taking the trace

$$f(x) = \frac{2}{d} \partial \cdot \epsilon. \quad (2.58)$$

Here  $d$  is the dimension of the space of the theory. Consider the case of flat euclidean metric  $g_{\mu\nu} = \eta_{\mu\nu} = \text{diag}(1, 1, \dots, 1)$ . After some manipulations of (2.57), like permuting the indices and applying an extra derivative, we find

$$[(d-2)\partial_\mu \partial_\nu + \eta_{\mu\nu} \square](\partial \cdot \epsilon) = 0, \quad (2.59)$$

which, contracted with  $\eta^{\mu\nu}$ , leads to

$$[(d-1)\square](\partial \cdot \epsilon) = 0. \quad (2.60)$$

From equations (2.59, 2.60) we can obtain all finite and infinitesimal transformations involved in  $d \geq 3$  dimensional systems. However in this thesis we are interested in two dimensional systems which represent a special case.

### 2.2.1 CFT in 2d

Consider the equation (2.57) for  $d = 2$ , in this case we find

$$\partial_1 \epsilon_1 = \partial_2 \epsilon_2, \quad \partial_1 \epsilon_2 = -\partial_2 \epsilon_1 \quad (2.61)$$

and

$$\partial_1 \epsilon_1 = -\partial_2 \epsilon_2, \quad \partial_1 \epsilon_2 = \partial_2 \epsilon_1. \quad (2.62)$$

We recognize the Cauchy-Riemann conditions for holomorphic (2.61) and antiholomorphic (2.62) functions. Now, we consider new complex variables

$$z = x^0 + ix^1, \quad \bar{z} = x^0 - ix^1 \quad (2.63)$$

and define

$$\epsilon(z) \equiv \epsilon^0 + i\epsilon^1, \quad \bar{\epsilon}(\bar{z}) \equiv \epsilon^0 - i\epsilon^1, \quad (2.64)$$

$$\partial \equiv \partial_z = \frac{1}{2}(\partial_0 - i\partial_1), \quad \bar{\partial} \equiv \partial_{\bar{z}} = \frac{1}{2}(\partial_0 + i\partial_1). \quad (2.65)$$

In these coordinates, we have

$$\partial \bar{\epsilon}(z) = 0, \quad \bar{\partial} \epsilon(\bar{z}) = 0. \quad (2.66)$$

It means that the general solution to these conditions is given by arbitrary functions of  $z$  in the first case, and by  $\bar{z}$  in the second case. So, the conformal transformations can be seen as a complex mapping

$$z \rightarrow w(z), \quad \bar{z} \rightarrow \bar{w}(\bar{z}), \quad (2.67)$$

where  $w(z)$  and  $\bar{w}(\bar{z})$  are arbitrary functions of  $z$  and  $\bar{z}$ . The set of analytic maps is infinite-dimensional because an infinite set of parameters is needed (coefficients of a Laurent series) to specify the analytic function in some neighborhood. This infinity makes  $2d$  conformal theory very powerful.

The infinitesimal conformal generators of the transformation 2.67 are

$$l_n = -z^{n-1}\partial, \quad \bar{l}_n = -\bar{z}^{n-1}\bar{\partial}, \quad n \in \mathbb{Z}, \quad (2.68)$$

They generate transformations of the form

$$z' = z + \epsilon(z) = z + \sum_{-\infty}^{\infty} c_n z^{n+1}. \quad (2.69)$$

The conformal generators satisfy the conformal algebra, given by the following commutation relations:

$$\begin{aligned} [l_n, l_m] &= (n-m)l_{n+m}; \\ [\bar{l}_n, \bar{l}_m] &= (n-m)\bar{l}_{n+m}; \\ [l_n, \bar{l}_m] &= 0. \end{aligned} \quad (2.70)$$

Note that the conformal algebra is the direct product of two sub-algebras generated by  $l_n$  and  $\bar{l}_n$ , we can treat  $z$  and  $\bar{z}$  as independent variables. This infinite-dimensional algebra contains a finite sub-algebra generated by  $l_0$ ,  $l_{-1}$  and  $l_1$ . This algebra remains well-defined in limits  $z \rightarrow 0, \infty$  and it is isomorphic to  $sl(2, \mathbb{C})$ . The generators of the algebra define the following independent transformations:

- translation  $z \rightarrow z + a$  generated by  $l_{-1}$  and  $\bar{l}_{-1}$ ;
- dilatation  $z \rightarrow \lambda z$  generated by  $l_0 + \bar{l}_0$ ;
- rotation  $z \rightarrow e^{i\theta} z$  generated by  $il_0 - i\bar{l}_0$ .

These three transformations, together, can be summarized as

$$z \rightarrow \frac{az + b}{cz + d}, \quad \text{with } ad - bc = 1, \quad (2.71)$$

where a,b,c and d are complex numbers.

## 2.2.2 Radial quantization and Virasoro algebra

Consider a CFT that lives on an infinite cylinder of radius R and is described by a complex variable  $w = x^0 + ix^1$ . Space dimension is described by the coordinate  $x^1$  and corresponds to a compactified dimension. In order to compute the radial quantization we perform the following conformal transformation

$$z = e^w = e^{x^0} e^{ix^1} \quad (2.72)$$

which maps the infinite cylinder to the complex plane. In this view, sections of the cylinder are mapped into orthogonal circles on the complex plane. Now, it is possible to define the radial ordering:

$$R[\varphi_1(w)\varphi_2(z)] = \begin{cases} \varphi_1(w)\varphi_2(z) & \text{if } |w| < |z| \\ \varphi_2(z)\varphi_1(w) & \text{if } |z| < |w|. \end{cases} \quad (2.73)$$

In CFT a very important role is played by the energy momentum tensor  $T_{\mu\nu}$  as it encodes symmetries and it can be used to construct conserved charges. This tensor is symmetric and in conformal invariant theories it is traceless:

$$T^\nu_\nu = 0. \quad (2.74)$$

Performing the complex change of coordinates, we find

$$\begin{aligned} T_{zz} &= \frac{1}{4}(T_{00} - 2iT_{10} - T_{11}), \\ T_{\bar{z}\bar{z}} &= \frac{1}{4}(T_{00} + 2iT_{10} - T_{11}), \\ T_{z\bar{z}} &= T_{\bar{z}z} = \frac{1}{4}T^\nu_\nu = 0. \end{aligned} \quad (2.75)$$

From the conservation of  $T$

$$\partial_0 T_{00} + \partial_1 T_{10} = \partial_0 T_{01} + \partial_1 T_{11} = 0, \quad (2.76)$$

we find

$$\partial_z T_{\bar{z}\bar{z}} = \partial_{\bar{z}} T_{zz} = 0. \quad (2.77)$$

Since  $T_{zz}$  depends only on  $z$  and  $T_{\bar{z}\bar{z}}$  depends only on  $\bar{z}$ , we define:  $T(z) \equiv T_{zz}$  and  $\bar{T}(\bar{z}) \equiv T_{\bar{z}\bar{z}}$ . The stress energy tensor can be Taylor-Laurent expanded in terms of the operators  $L_n$

$$T(z) = \sum_{-\infty}^{\infty} \frac{L_n}{z^{n+2}}. \quad (2.78)$$

Inverted for  $L_n$ , this relation reads

$$L_n = \frac{1}{2\pi i} \oint_C dz z^{n+1} T(z), \quad (2.79)$$

whose action on some conformal field  $\phi(w, \bar{w})$  leads to the equation

$$L_n \phi(w, \bar{w}) = \frac{1}{2\pi i} \oint_{C_w} dz (z-w)^{n+1} T(z) \phi(w, \bar{w}). \quad (2.80)$$

The integral is evaluated on the contour around the point  $w$ . Another important property of  $L_n$ 's and  $\bar{L}_n$ 's comes from hermiticity of the energy momentum tensor (which is necessary in unitary theories)

$$L_n^\dagger = L_{-n}, \quad \bar{L}_n^\dagger = \bar{L}_{-n}. \quad (2.81)$$

In CFT, the concept of *Operator Product Expansion (OPE)* is crucial. It is a description of what happens when the separation between two local operators becomes very small. The idea of OPE is that two local operators near some point  $z$  can be described by a set of operators at point  $z$ . Consider all local operators of a CFT  $\mathcal{O}_i$ , the OPE is

$$\mathcal{O}_i(z, \bar{z}) \mathcal{O}_j(w, \bar{w}) = \sum_k C_{ij}^k \mathcal{O}_k(w, \bar{w}) \quad (2.82)$$

where  $C_{ij}^k$  are a set of functions which depend only on the separation between variables  $(z-w, \bar{z}-\bar{w})$ . The OPE of the energy momentum tensor with itself reads

$$T(z)T(w) = \frac{c/2}{(z-w)^4} + \frac{2T(w)}{(z-w)^2} + \frac{\partial_w T(w)}{z-w} + \dots \quad (2.83)$$

where  $c$  is the so-called *central charge* of the CFT and depends on the particular model under consideration. A similar result holds for  $\bar{T}(z)\bar{T}(w)$  and in  $T(z)\bar{T}(w)$  appear only non singular terms.

Now, if we apply twice the operator  $L_n$  on some conformal field and subtract the permutation, we can evaluate the commutation relations for  $L_n$ . Using (2.83) in this calculation, we obtain

$$\begin{aligned} [L_n, L_m] &= (n-m)L_{n+m} + \frac{c}{12}n(n^2-1)\delta_{n+m,0}, \\ [\bar{L}_n, \bar{L}_m] &= (n-m)\bar{L}_{n+m} + \frac{c}{12}n(n^2-1)\delta_{n+m,0}, \\ [\bar{L}_n, L_m] &= 0. \end{aligned} \tag{2.84}$$

These relations are called *Virasoro algebra* and they represent the quantum extension of the conformal algebra (2.70), note that if  $c = 0$  the two algebras coincide.

### 2.2.3 Primary fields and correlation functions

In CFT it is extremely important to know the primary fields content of a specific conformal model. Consider some conformal map of the form  $z \rightarrow f(z)$  and  $\bar{z} \rightarrow f(\bar{z})$ . A quantity  $\varphi(z, \bar{z})$  under this map may transform in the simplest “tensorial” way:

$$\varphi(z, \bar{z}) = \left(\frac{df}{dz}\right)^\Delta \left(\frac{d\bar{f}}{d\bar{z}}\right)^{\bar{\Delta}} \varphi'(z', \bar{z}') \tag{2.85}$$

where the two real parameters  $\Delta$  and  $\bar{\Delta}$  are called *conformal weights* or *conformal dimensions*. Fields which satisfy such kind of transformation are known as *primary fields*. All others fields which do not fulfill the property (2.85), for example the energy momentum tensor, are called *secondary* or *descendant fields*. In the context of statistical mechanics, there is a correspondence between the weights of primary operators and critical exponents. The OPE of  $T$  and  $\bar{T}$  with a primary operator is

$$\begin{aligned} T(z)\varphi(w, \bar{w}) &= \Delta \frac{\varphi(w, \bar{w})}{(z-w)^2} + \frac{\partial\varphi(w, \bar{w})}{z-w} + \text{non-singular}, \\ \bar{T}(\bar{z})\varphi(w, \bar{w}) &= \bar{\Delta} \frac{\varphi(w, \bar{w})}{(\bar{z}-\bar{w})^2} + \frac{\bar{\partial}\varphi(w, \bar{w})}{\bar{z}-\bar{w}} + \text{non-singular}. \end{aligned} \tag{2.86}$$

In CFT two useful parameters are *the spin*  $s := \Delta - \bar{\Delta}$  which is the eigenvalue under rotations and *the scale dimension*  $d := \Delta + \bar{\Delta}$  which represents the physical dimension of an operator.

Consider a correlation function of  $n$  primary operators which under (2.85) transforms as

$$\begin{aligned} \langle \varphi_1(z_1, \bar{z}_1), \dots, \varphi_n(z_n, \bar{z}_n) \rangle &= \\ \prod_{i=1}^n \left(\frac{dz}{dw}\right)_{z=z_i}^{-\Delta_i} \left(\frac{d\bar{z}}{d\bar{w}}\right)_{\bar{z}=\bar{z}_i}^{-\bar{\Delta}_i} \langle \varphi_1(w_1, \bar{w}_1), \dots, \varphi_n(w_n, \bar{w}_n) \rangle. \end{aligned} \tag{2.87}$$

Using this relation and the conformal invariance, it is possible to fix two-point and three-point functions. The two-point correlation function reads

$$\langle \varphi_1(z_1, \bar{z}_1), \varphi_2(z_2, \bar{z}_2) \rangle = \mathcal{C}(z_1 - z_2)^{-2\Delta}(\bar{z}_1 - \bar{z}_2)^{-2\bar{\Delta}} \quad (2.88)$$

where  $\Delta \equiv \Delta_1 = \Delta_2$  and  $\bar{\Delta} \equiv \bar{\Delta}_1 = \bar{\Delta}_2$ , the correlation function vanishes if  $\Delta_1 \neq \Delta_2$  and  $\bar{\Delta}_1 \neq \bar{\Delta}_2$ ,  $\mathcal{C}$  is some normalization constant. Imposing the rotation, translation, and dilatation invariance, we obtain the three-point correlation function:

$$\begin{aligned} & \langle \varphi_1(z_1, \bar{z}_1), \varphi_2(z_2, \bar{z}_2), \varphi_3(z_3, \bar{z}_3) \rangle = \\ & \mathcal{C}(z_1 - z_2)^{-(\Delta_1 + \Delta_2 - \Delta_3)}(z_2 - z_3)^{-(\Delta_2 + \Delta_3 - \Delta_1)}(z_1 - z_3)^{-(\Delta_1 + \Delta_3 - \Delta_2)} \times \\ & (\bar{z}_1 - \bar{z}_2)^{-(\bar{\Delta}_1 + \bar{\Delta}_2 - \bar{\Delta}_3)}(\bar{z}_2 - \bar{z}_3)^{-(\bar{\Delta}_2 + \bar{\Delta}_3 - \bar{\Delta}_1)}(\bar{z}_1 - \bar{z}_3)^{-(\bar{\Delta}_1 + \bar{\Delta}_3 - \bar{\Delta}_2)}. \end{aligned} \quad (2.89)$$

Using the conformal invariance it is not possible to fix completely the four-point (or higher-point) correlation functions. In these functions appear undetermined anharmonic ratios which are functions, invariant under the conformal group.

## 2.2.4 Hilbert space and highest weight representation

In order to define the Hilbert space of the a conformal theory we start analyzing the action of the energy-momentum operator on the vacuum state:

$$T(z) |0\rangle = \sum_{-\infty}^{\infty} \frac{L_n}{z^{n+2}} |0\rangle \quad (2.90)$$

it is easy to see that the regularity, at  $z = 0$ , is preserved if

$$L_n |0\rangle = 0, \quad n \geq -1. \quad (2.91)$$

The same statement holds for antiholomorphic part of the energy-momentum tensor  $\bar{T}(\bar{z})$  and generators  $\bar{L}_n$ . In particular, relations

$$L_{\pm 1,0} |0\rangle = 0 \quad \text{and} \quad \bar{L}_{\pm 1,0} |0\rangle = 0 \quad (2.92)$$

ensure the invariance of the vacuum state under global conformal transformations. The property (2.81) implies

$$\langle 0 | L_n = 0, \quad n \leq -1. \quad (2.93)$$

Using the OPE (2.86) and the definition of the energy momentum tensor (2.78), it is possible to derive

$$[L_n, \varphi(z, \bar{z})] = \Delta(n+1)z^n \varphi(z, \bar{z}) + z^{n+1} \partial \varphi(z, \bar{z}) \quad n \geq -1, \quad (2.94)$$



where  $\varphi(z, \bar{z})$  is a primary field of dimensions  $(\Delta, \bar{\Delta})$ . This implies that

$$[L_n, \varphi(0, 0)] = 0, \quad n = 0 \quad (2.95)$$

and

$$[L_0, \varphi(0, 0)] = \Delta \varphi(0, 0), \quad n = 0. \quad (2.96)$$

Suppose now, to have some asymptotic state created by the action of some primary operator of conformal weight  $\Delta$  (for the sake of simplicity let consider only the analytic part of the theory) on ground state

$$|\Delta\rangle \equiv \varphi(0, 0) |0\rangle. \quad (2.97)$$

Using (2.95) and (2.96) we conclude that

$$\begin{aligned} L_0 |\Delta\rangle &= \Delta |\Delta\rangle \\ L_n |\Delta\rangle &= 0, \quad n > 0. \end{aligned} \quad (2.98)$$

The states satisfying the previous properties are called *highest weight states*.

Using the asymptotic state (2.97), it is possible generate an infinite number of *descendant states* of higher conformal dimension. These are generated by the application of the operator  $L_n$  with negative  $n$ , for example

$$L_{-n_1} L_{-n_2} \dots L_{-n_k} |\Delta\rangle, \quad n_i > 0, \quad i = 1, \dots, k. \quad (2.99)$$

The eigenvalue of the operator  $L_0$ , applied on the descendant state, is  $(\Delta + N)$  where  $N = \sum_{i=1}^k n_i$ . The infinite tower of descendant states of some asymptotic state  $|\Delta\rangle$  is called *Verma module*. For instance, the lowest three levels of the Verma module are

$$\begin{aligned} &L_{-1} |\Delta\rangle \\ &L_{-2} |\Delta\rangle, \quad L_{-1}^2 |\Delta\rangle \\ &L_{-3} |\Delta\rangle, \quad L_{-1} L_{-2} |\Delta\rangle, \quad L_{-1}^3 |\Delta\rangle. \end{aligned} \quad (2.100)$$

Not all states of the Verma module are independent of each other. The linear combinations of states that vanish are called *null states*. Null states generally depend on the central charge  $c$  and conformal weight of the highest weight  $\Delta$ . The construction of an irreducible representation of the Virasoro algebra with the highest weight  $\Delta$  is made by removing all null states from the Verma module.

## 2.2.5 Unitary models, minimal models and Kac determinant

In physics a very important requirement is unitarity. This statement implies the conservation of probability in Minkowski space-time and Hermitian Hamiltonian. In CFT a Hamiltonian is called Hermitian if the following requirement is satisfied

$$L_n = L_{-n}^\dagger. \quad (2.101)$$

Another way to require unitarity is to impose to states to have non negative norm. Since the norm depends on the highest weight  $\Delta$  and the central charge  $c$ , values of these parameters determine whether the representation is unitary or not.

- Central charge. Consider

$$\langle \Delta | L_n L_{-n} | \Delta \rangle = \langle \Delta | [L_n, L_{-n}] | \Delta \rangle = [2n\Delta + \frac{c}{12}n(n^2 - 1)] \langle \Delta | \Delta \rangle \quad (2.102)$$

and set  $\Delta = 0$ . The requirement to have a positive norm is  $c \geq 0$ .

- Highest weight. Consider the norm

$$\langle \Delta | L_1 L_{-1} | \Delta \rangle = \langle \Delta | [L_1, L_{-1}] | \Delta \rangle = 2\Delta \langle \Delta | \Delta \rangle. \quad (2.103)$$

The requirement is  $\Delta \geq 0$ .

A general method to find the null states consists in studying the so-called *Kac determinant*. The Kac determinant is defined as the determinant of the *Gram matrix*, which is a matrix of inner products between all basis states. The lowest two levels of the Gram matrix are

$$M^{(1)} = \langle \Delta | L_1 L_{-1} | \Delta \rangle = 2\Delta \langle \Delta | \Delta \rangle, \quad (2.104)$$

$$M^{(2)} = \langle \Delta | \begin{pmatrix} L_{-2}^\dagger L_{-2} & L_{-2}^\dagger L_{-1}^2 \\ (L_{-1}^2)^\dagger L_{-2} & (L_{-1}^\dagger)^\dagger L_{-1}^2 \end{pmatrix} | \Delta \rangle = \begin{pmatrix} 4\Delta(2\Delta + 1) & 6\Delta \\ 6\Delta & 4\Delta + c/2 \end{pmatrix} \langle \Delta | \Delta \rangle. \quad (2.105)$$

The search of the null states corresponds to require the Kac determinant to vanish. So, at first level we have the solution  $\Delta_{1,1} = 0$ , and at the second level

$$\begin{aligned} \det M^2 &= 32\Delta \left( \Delta^2 - \frac{5\Delta}{8} + \frac{\Delta c}{8} + \frac{c}{16} \right) = \\ &= 32(\Delta - \Delta_{1,1})(\Delta - \Delta_{1,2})(\Delta - \Delta_{2,1}) \end{aligned} \quad (2.106)$$

where

$$\begin{aligned} \Delta_{1,1} &= 0, \\ \Delta_{(1,2),(2,1)} &= \frac{1}{16} (5 - c \mp \sqrt{(1-c)(25-c)}). \end{aligned} \quad (2.107)$$

The general formula which gives Kac determinant reads

$$\det M^N = C_N \prod_{\substack{r,s \geq 1 \\ rs \leq N}} [\Delta - \Delta_{r,s}]^{P(N-rs)}, \quad (2.108)$$

where  $P(N - rs)$  is the number of partitions of the integer number (N-rs) and  $C_N$  is some positive constant. One of the possible parameterizations for roots of Kac determinant is

$$\begin{aligned}\Delta_{r,s}(c) &= \Delta_0 + \frac{1}{4}(r\alpha_+ + s\alpha_-)^2, \\ \Delta_0 &= \frac{1}{24}(c - 1) \\ \alpha_{\pm} &= \frac{\sqrt{1 - c} \pm \sqrt{25 - c}}{\sqrt{24}}.\end{aligned}\tag{2.109}$$

It is interesting to study the so-called vanishing curves. The Kac determinant in the  $(c, h)$  plane, vanishes along these curves.

In the interval  $0 < c < 1$ ,  $\Delta > 0$ , the unitary representations correspond only to discrete set

$$\begin{aligned}c &= 1 - \frac{6}{m(m+1)}, \quad m = 2, 3, 4, \dots \\ \Delta_{r,s}(m) &= \frac{[(m+1)r - ms]^2 - 1}{4m(m+1)}, \quad 1 \leq r \leq m, \quad 1 \leq s \leq m+1.\end{aligned}\tag{2.110}$$

The discrete values of conformal weights and the central charges define the so-called *conformal minimal models* denoted by  $\mathcal{M}_m$ . These models correspond to the continuum limit of the statistical models at their critical point. For example, to the three first models correspond the Ising model ( $m = 3$ ,  $c = \frac{1}{2}$ ), the tricritical Ising model ( $m = 4$ ,  $c = \frac{7}{10}$ ) and the 3-state Potts model ( $m = 5$ ,  $c = \frac{4}{5}$ ).

## 2.2.6 Integrals of motion

In the CFT the integrals of motions usually are constructed starting from the energy momentum tensor, this is due to the fact that this tensor at the conformal point is trivially conserved (2.77). Consider the equation (2.80), in the case of  $\phi(z, \bar{z}) = \mathcal{I}$ , we see that

$$L_{-2}\mathcal{I} = \frac{1}{2\pi i} \oint dw \frac{T(w)}{w - z} = T(z).\tag{2.111}$$

More generally, the application of the operator  $L_n$  with  $n \leq -2$  lead to

$$(L_{-n}\mathcal{I})(z) = \frac{1}{(n-2)!} \partial_z^{n-2} T(z).\tag{2.112}$$

Successive applications with more than one operator  $L_{-n}$  on the identity operator produce composite fields made by energy momentum operators and its derivatives. For instance,

$$T_4(z) =: T^2(z) := (L_{-2}L_{-2}\mathcal{I})(z) = \frac{1}{2\pi i} \oint dw \frac{T(w)T(z)}{(w - z)}.\tag{2.113}$$

All fields constructed in this way give rise to an infinite dimensional space  $\Lambda$  of conservation laws. The space  $\Lambda$  can be decomposed as follows

$$\Lambda = \bigoplus_{s=0}^{\infty} \Lambda_s \quad (2.114)$$

where the fields  $\Lambda_s$  are conserved:

$$\partial_{\bar{z}} \Lambda_s(z) = 0. \quad (2.115)$$

and they are eigenvalues of  $L_0$  and  $\bar{L}_0$ :

$$L_0 \Lambda_s = s \Lambda_s, \quad \bar{L}_0 \Lambda_s = 0. \quad (2.116)$$

There are some fields which are total derivatives

$$\tilde{\Lambda}_s = \partial_z \Lambda_{s-1}. \quad (2.117)$$

In order to construct a space of linear independent fields it is convenient to eliminate the total derivatives. So, we consider the space defined as

$$\hat{\Lambda} = \Lambda / L_{-1} \Lambda. \quad (2.118)$$

which presents the same decomposition of  $\Lambda$  and satisfy (2.116). In the conformal space the operator  $L_{-1}$  acts as derivative. The dimensionalities of  $\hat{\Lambda}_s$  can be computed by the character of the Virasoro algebra corresponding to the irreducible representation of  $\Lambda$ , the character formula reads

$$\sum_{s=0}^{\infty} q^s \dim(\hat{\Lambda}_s) = (1-q)\chi_0(q) + q \quad (2.119)$$

where  $\chi_0$  is the character of  $\hat{\Lambda}_s$ . Call  $\mathcal{T}_s^{(k)}$  some field of  $\hat{\Lambda}_s$ , this field can be expanded as

$$\begin{aligned} \mathcal{T}_s^{(k)} &= \sum_{n \in \mathbb{Z}} z^{-n-s} \mathcal{L}_{s,n}^{(k)}, \\ \mathcal{L}_{s,n}^{(k)} &= \frac{1}{2\pi i} \oint dw (w-z)^{n+s-1} \mathcal{T}_s^{(k)}. \end{aligned} \quad (2.120)$$

Finally, we can represent an infinite set of linearly independent integrals of motion as

$$(\mathcal{L}_{s,n}^{(k)} A)(z, \bar{z}) = \frac{1}{2\pi i} \oint dw (w-z)^{n+s-1} \mathcal{T}_s^{(k)}(w) A(z, \bar{z}) \quad (2.121)$$

where  $n = \pm 1, \pm 2, \dots$ . There exist an important class of QFT's which can be understood as perturbations of CFT's. The key idea of the perturbed CFT theory is that under some very specific conditions, some of the conservation laws of unperturbed theory, can survive after the CFT has been perturbed.

## 2.2.7 Perturbed Conformal Field Theories

The integrable perturbed CFT's were widely analyzed by A. B. Zamolodchikov in the paper [24]. A CFT corresponds to a fixed point of renormalization group. These theories can be described by the following action

$$S = S_{CFT} + \lambda \int d^2x \varphi(x^0, x^1) \quad (2.122)$$

where  $S_{CFT}$  is the original CFT,  $\varphi(x^0, x^1)$  is a primary field of the  $S_{CFT}$  with conformal dimension  $(\Delta, \bar{\Delta})$ . We will assume the conformal dimension of the perturbing operator to be positive (corresponds to the case of unitary models) and we also set  $\Delta = \bar{\Delta}$ , it means that the field  $\varphi(x^0, x^1)$  is spinless and has the scaling dimension  $d = 2\Delta$ . In order to drive a theory away from the fixed point the perturbing field must be a relevant field with  $\Delta < 1$ . The parameter  $\lambda$  is the coupling constant which determines the direction of the shift. This parameter carries a scalar mass dimension  $[\lambda] = (m^2)^{1-\Delta}$  or in terms of left and right dimensions  $(1 - \Delta, 1 - \Delta)$ .

A CFT contains a space of local fields. In order to proceed to analyze the perturbed theory we have to make the assumption that the local fields content of the original CFT is enough to describe also the perturbed CFT. In general, the fields of a perturbed field theory need infinite renormalizations. However the relevant perturbation of a CFT corresponds to super-renormalizable interactions. This translates in the fact that it is enough to add only a finite number of terms, which contains fields with lower dimension, to each local field. At the end of the day we will see that the space of local fields of the perturbed theory will have the same structure of the original CFT.

Consider a field  $\mathcal{T}_s \in \hat{\Lambda}$ , instead of being conserved

$$\partial_{\bar{z}} \mathcal{T}_s^{(k)} = 0, \quad (2.123)$$

as in free theory, in the case of perturbation this equation becomes

$$\partial_{\bar{z}} \mathcal{T}_s^{(k)} = \lambda \mathcal{R}_{s-1}^{(k)1} + \dots + \lambda^n \mathcal{R}_{s-1}^{(k)n} + \dots \quad (2.124)$$

where  $\mathcal{R}_{s-1}^{(k)n}$  are some local fields of the Virasoro algebra. Let's do the dimensional analysis of this relation. On the left hand side we have  $(s, 1)$ , this has to match with those in right hand side. It is clear that the dimensions of the fields  $\mathcal{R}_{s-1}^{(k)n}$  are

$$(s - n\epsilon, 1 - n\epsilon), \quad \epsilon \equiv 1 - \Delta. \quad (2.125)$$

We can deduce that for some large value of  $n$  the right dimension of  $\mathcal{R}_{s-1}^{(k)n}$  become negative but there are no fields with negative dimensions so the series (2.123) must truncate. In most cases only the first term survives, as we assume from now

$$\partial_{\bar{z}} \mathcal{T}_s^{(k)} = \lambda \mathcal{R}_{s-1}^{(k)}. \quad (2.126)$$

So, the conservation laws for the CFT (2.123) are mapped into the new equations (2.126) for relevant and spinless fields.

The next step consists in the identification of the local field  $R_{s-1}^{(k)n}$ . It can be achieved by studying the correlation functions of the perturbed CFT. Any correlation function involving  $\mathcal{T}_s^k(z)$ , at first order correction reads

$$\langle \mathcal{T}_s^k(z), \dots \rangle = \langle \mathcal{T}_s^k(z), \dots \rangle_{CFT} + \int d\xi d\bar{\xi} \langle \varphi(\xi, \bar{\xi}), \mathcal{T}_s^k(z), \dots \rangle \quad (2.127)$$

We are interested in the behavior in the vicinity of singular point  $(\xi, \bar{\xi}) \rightarrow (z, \bar{z})$ , where we can use the OPE

$$\mathcal{T}_s^k(z) \varphi(\xi, \bar{\xi}) = \sum_{n=0}^{\infty} (z - \xi)^{n-s} (\mathcal{L}_{s,-n}^{(k)} \varphi)(\xi, \bar{\xi}) \quad (2.128)$$

where  $\mathcal{L}_{s,-n}^{(k)} \varphi$  are some local fields. Then, if one takes into account the relation

$$\partial_{\bar{z}} (\xi - z)^{-m-1} = -2\pi i \frac{1}{m!} \partial_z^m \delta^2(z - \xi) \quad (2.129)$$

the equation (2.126) becomes

$$\lambda \mathcal{R}_{s-1}^k(z, \bar{z}) = \partial_{\bar{z}} \mathcal{T}_s^k(z, \bar{z}) = \frac{\lambda}{2\pi i} \oint_z \varphi(\xi, \bar{z}) \mathcal{T}_s^k(z). \quad (2.130)$$

This integral, around a small contour, is equal to a commutator

$$\partial_{\bar{z}} \mathcal{T}_s^k(z, \bar{z}) = [T_s^{(k)}, H_{int}] \quad (2.131)$$

with

$$H_{int} = \lambda \int d\xi \varphi(\xi, \bar{z}). \quad (2.132)$$

In order to do explicit calculations it is useful to introduce operators

$$D_n \Lambda(z, \bar{z}) = \frac{1}{2\pi i} \oint_z d\xi \varphi(\xi, \bar{z}) (\xi - z)^n \Lambda(z) \quad (2.133)$$

with  $D_0 = \partial_{\bar{z}}$ . The primary fields satisfy the equations

$$[L_n, \varphi(\xi, \bar{\xi})] = \{(\xi - z)^{n+1} \partial_{\xi} + \Delta(n+1)(\xi - z)^n\} \varphi(\xi, \bar{\xi}), \quad (2.134)$$

which allow to prove the commutation relations

$$[L_n, D_m] = -((1 - \Delta)(n+1) + m) D_{n+m} \quad (2.135)$$

and

$$D_{-m} \mathcal{I} = \frac{1}{(m+1)!} L_{-1}^{m+1} \varphi(z, \bar{z}). \quad (2.136)$$

Using these equations, it is easy to compute  $\mathcal{R}_{s-1}^k$ . For instance, consider

- $\mathcal{T}_2 = T$ , we obtain

$$\begin{aligned}\partial_{\bar{z}}T &= \lambda D_0 L_{-2} \mathcal{I} = \lambda(\Delta - 1)L_{-1}\varphi = \partial_z \Theta, \\ \Theta &= \lambda(\Delta - 1)\varphi.\end{aligned}\tag{2.137}$$

We recover the conservation relation for energy momentum operator.

- $\mathcal{T}_4$

$$\begin{aligned}\partial_{\bar{z}}\mathcal{T}_4 &= \lambda(\Delta - 1)(D_{-2}L_{-2} + L_{-2}D_{-2})\mathcal{I} = \\ &\lambda(\Delta - 1)\left(-2L_{-3} + 2L_{-1}L_{-2} + \frac{\Delta - 3}{6}L_{-1}^3\right)\varphi.\end{aligned}\tag{2.138}$$

Generically, the right hand side is not a total derivative and there is no conservation law. However, if we define the perturbing field  $\varphi$  to be the field  $\varphi_{1,3}$ , we can use the null vector equation at level 3 to re-express  $L_{-3}$  and obtain a conservation law in the form

$$\partial_{\bar{z}}\mathcal{T}_4 = \partial_z \Theta_2.\tag{2.139}$$

It is clear that the field  $\mathcal{T}_s$  is conserved only if  $\mathcal{R}_{s-1}$  is a total derivative,

$$\mathcal{R}_{s-1} = \partial_z \Theta_{s-2}\tag{2.140}$$

and the conservation in the perturbation theory will have the following form

$$\partial_{\bar{z}}\mathcal{T}_s = \partial_z \Theta_{s-2}.\tag{2.141}$$

So, the procedure discussed so far gives us all tools needed to compute integrals of motion of the perturbed CFT. Now we need a principle to establish if a perturbed theory is an integrable theory. This was been developed by A. B. Zamolodchikov and goes under the name of *counting argument* which is formulated as follows: Consider the conservation law (2.126), we can reinterpret this equation as a linear map

$$f_s : \hat{\Lambda}_s \rightarrow \hat{\Lambda}_{s-1}\tag{2.142}$$

where  $\mathcal{T}_s \in \Lambda_s$  and  $\mathcal{R}_{s-1} \in \Lambda_{s-1}$ . This map will have a non trivial kernel each time that

$$\dim \hat{\Lambda}_s > \dim \hat{\Lambda}_{s-1}\tag{2.143}$$

with the consequence that some field  $\mathcal{T}_s$  and some field  $\mathcal{R}_{s-1}$  which satisfy (2.126) will exist. The counting argument allows to prove the quantum integrability by comparing dimensions of spaces without explicit computations of integrals of motion. The dimensions of the involving spaces can be computed by using the conformal characters.

## CHAPTER 3

---

### Thermodynamic Bethe ansatz

---

In this section we discuss the thermodynamic Bethe ansatz [25, 26, 27] and illustrate how it allows to analyze the thermodynamics of infinite volume integrable massive QFT's. For this purpose we need only two ingredients which are S-matrix and mass spectrum of the theory. The TBA produce a set of non-linear integral equations which solutions are used in the computation of energy and other thermodynamic quantities.

In order to confirm that a S-matrix is describing the considered theory one have to extract the information from the UV limit. This can be done using *Thermodynamic Bethe Ansatz (TBA)*, which also allows to compute the thermodynamics of a theory. In the case of diagonal S-matrices, the TBA is easy to formulate. It has been noted by Al. Zamolodchikov that one class of TBA's is related the A, D, E algebras. The structure of these TBA's emerges from the Dynking's diagrams, where each node represents a particle. One may, then, adopt a reverse strategy, therefore one can construct a diagram first, and then compute the UV-limit. This procedure allows to detect the central charge of the CFT and the perturbing operator.

More generally the S-matrix is non-diagonal, we have to apply more tricky methods involving Algebraic Bethe Ansatz. The structure of these theories is a little bit different. In fact, the Dynking diagrams present some nodes that are attached to quantities with no energy and no momenta. These are the fictitious particles called *magnons*, introduced to exchange the internal degree of freedoms between the physical particles.

An important class of theories are given by massive integrable perturbations of the coset  $(A_{m-1})_k \times (A_{m-1})_l / (A_{m-1})_{k+l}$  with the relevant operator known as  $\phi_{1,1,adj}$ . It is conjectured that this kind of theories are described by a tensor product of two simply laced algebras  $A_{m-1}$ . These algebras are associated with *trigonometric S-matrices*. Two significant examples, in the case  $m = 2$ , are perturbed conformal minimal models ( $k > 1$ ,



$l = 1$ ) and perturbed superconformal minimal models ( $k > 1, l = 2$ ).

The S-matrix theory and TBA are strictly related to the Lie algebras. In the Appendix C it will be presented some key points of Lie algebras. For deeper understanding one can read the book ([40]) where the Lie algebras are widely treated from the physical point of view.

### 3.1 TBA for diagonal S-matrices

Consider a scattering theory, on a circle of circumference  $L$ , and consider  $N$  particles  $N_\alpha$ , of species  $\alpha$ , at positions  $x_1, \dots, x_N$ . Assume also that the scattering theory is purely elastic so the theory is a (1+1)-dimensional QFT described by diagonal and factorizable S-matrix. Imagine the  $L$  to be large enough that there are regions (free regions) where all particles are strongly separated and don't interact. Specifically, we consider  $|x_i - x_j| \gg R_c$ , where  $R_c = 1/m_i$  is the correlation length. This situation can be described by the asymptotic wave function of the form

$$\psi(x_1, \dots, x_N) = \exp(i \sum_i p_i x_i) \sum_{Q \in S_N} A(Q) \Theta(x_Q) \quad (3.1)$$

where  $S_N$  is the set of all  $N!$  permutations of  $N$  particles on the circle and  $\Theta(x_Q)$  defines the ordering as

$$\Theta(x_Q) = \begin{cases} 1 & \text{if } x_{Q_1} < \dots < x_{Q_N} \\ 0 & \text{otherwise.} \end{cases}$$

The coefficients  $A(Q)$  are determined by the S-matrix

$$A(Q') = S_{ij}(\theta_i - \theta_j) A(Q) \quad (3.2)$$

where  $S_{ij}$  exchanges the indices  $i$  and  $j$  of the configuration  $Q$ , i.e.  $\{\dots, i, j, \dots\} \rightarrow \{\dots, j, i, \dots\}$ .

Now, if we impose (anti)periodic boundary conditions to the wave function

$$\psi(\dots, x_i = L, \dots) = (-1)^{F_i} \psi(\dots, x_i = 0, \dots) \quad \text{for } i = 1, 2, \dots, N \quad (3.3)$$

we obtain

$$A(i, Q_2, \dots, Q_N) = (-1)^{F_i} e^{ip_i L} A(Q_2, \dots, Q_N, i) \quad (3.4)$$

for any  $Q \in S_N$  such that  $Q_1 = i$ .  $(-1)^{F_i} = \pm$  indicates if the particle is a boson or fermion, respectively. If we put together equations (3.2) and (3.4), we obtain:

$$e^{iLm_i \sinh(\theta_i)} \prod_{j:j \neq i} S_{ij}(\theta_i - \theta_j) = (-1)^{F_i} \quad \text{for } i = 1, 2, \dots, N, \quad (3.5)$$

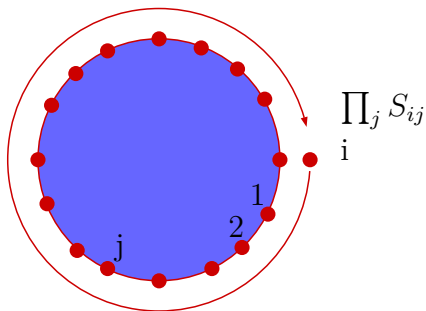

Figure 3.1: The wave function should not change if the particle completes the walk around the circle.

or equivalently taking the logarithm at both sides leads to

$$Lm_i \sinh \theta_i + \sum_{j:j \neq i} \delta_{ij}(\theta_i - \theta_j) = 2\pi n_i \quad \text{for } i = 1, 2, \dots, N \quad (3.6)$$

where

$$\delta_{ij}(\theta_i - \theta_j) = -i \log S_{ij}(\theta_i - \theta_j) \quad (3.7)$$

is the phase shift. So, these are a set of  $N$  coupled transcendental equations for the rapidities, the Bethe equations. The  $\{n_i\}$  can be interpreted as a set of quantum numbers of a multi-particle system where

- if  $n_i \in \mathbb{Z}$  is the bosonic case,
- if  $n_i \in \mathbb{Z} + \frac{1}{2}$  is the fermionic case.

The Bethe equations select a set of admissible rapidities  $(\theta_1, \dots, \theta_N)$  which are called roots. The set of rapidities with associated “skipped” values of  $n_i$  are called holes.

Another selection rule comes out from the unitarity condition of S-matrix:  $S^2(0) = 1$ . This means that two cases are possible:

- $S(0) = -1$ . Two bosons are not allowed to have the same rapidity and they behave as fermionic type particles. Fermions have no restrictions and they said to be of bosonic type.
- $S(0) = 1$ . Here there are no restrictions on bosons and identical fermions are not allowed to have the same rapidity.

The previous rules can be condensed into the particle type variable defined as

$$t_i = -(-1)^{F_i} S_{ii}(0) = \pm 1 \quad (3.8)$$

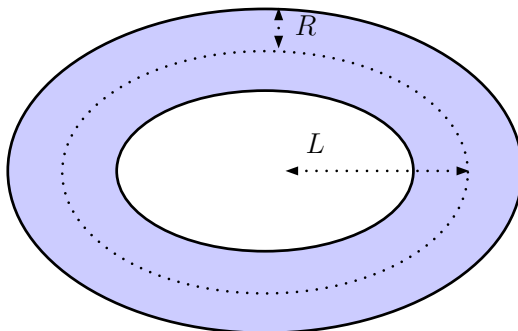

Figure 3.2: Torus of circumferences  $R$  and  $L$ .

corresponds to 1 if the particle is of boson type and to  $-1$  if it is of fermion type.

We are considering a relativistic systems so, the energy and the momentum of the state  $|\theta_1, \dots, \theta_N\rangle$ , for particles with mass  $m_i$ , are given by

$$H = \sum_{i=1}^N m_i \cosh(\theta_i), \quad P = \sum_{i=1}^N m_i \sinh(\theta_i). \quad (3.9)$$

### 3.1.1 Mirror Thermodynamics

Consider our system to be a QFT on a torus of circumference  $R$  and  $L$  (3.2). We have two possible choices for the quantization axis. In fact, from the topological point of view, the Hamiltonian can be constructed through two formulations, namely we can choose the time direction along

- $L$ . Taking  $L \rightarrow \infty$  and keeping  $R$  finite, the partition function of the field theory  $Z(R, L)$  is dominated by the ground state energy  $E(R)$

$$Z(R, L) \sim \lim_{L \rightarrow \infty} \text{Tr}_{\mathcal{H}_R} e^{-iH_R L} \sim e^{-E(R)L}. \quad (3.10)$$

- $R$ . The partition function, in the  $L \rightarrow \infty$  limit describes the theory with periodic time, i.e. finite temperature  $T = 1/R$ .

$$Z(R, L) \sim \lim_{L \rightarrow \infty} \text{Tr}_{\mathcal{H}_L} e^{-iH_L R} \sim e^{-LRf(R)} \quad (3.11)$$

where  $f(R)$  is the free energy per unit length.

By comparing two partition functions we obtain

$$E(R) = Rf(R). \quad (3.12)$$

This relation holds only in relativistic systems since it represents the direct consequence of the Wick rotation. It is also possible to evaluate the  $UV$  limit  $R \rightarrow 0$  which leads to some conformal theory. In this limit the ground state energy reads

$$\lim_{R \rightarrow 0} E(R) = -\frac{\pi c_{eff}}{6R}, \quad c_{eff} = c - 24\Delta \quad (3.13)$$

where  $c_{eff}$  is the effective central charge,  $c$  is the central charge of the conformal theory and  $\Delta$  is the lowest scaling dimension of the CFT.

### 3.1.2 Thermodynamic limit

In the thermodynamic limit

$$L \rightarrow \infty, \quad N \rightarrow \infty, \quad N/L = \text{fixed}, \quad (3.14)$$

due to the growing number of the particles, the spectrum of rapidities condense and the distance between adjacent rapidities behaves as  $\theta_i - \theta_{i+1} \sim 1/mL$ . For the sake of simplicity, we will consider the systems with only one type of particles, the generalization is straightforward. In the thermodynamic limit it makes sense to define the density of particles  $\rho^{(p)}$  and the density of states  $\rho$  as

$$\rho = \frac{\Delta n}{\Delta \theta}, \quad \rho^{(p)} = \frac{\Delta k}{\Delta \theta} \quad (3.15)$$

where  $\Delta n = n_i - n_{i-1}$  and  $\Delta k = k_i - k_{i-1}$ . These are, respectively, the numbers of allowed states and the number of allowed particles, which lie in the interval  $[\theta_{i-1}, \theta_i]$ . These densities are useful to evaluate the continuous limit of discrete quantities,

$$\sum_i^N f(\theta_i) = \int d\theta \rho(\theta) f(\theta). \quad (3.16)$$

For example, the energy reads

$$H(\rho^{(p)}) = \int d\theta \rho^{(p)}(\theta) m \cosh(\theta). \quad (3.17)$$

In the Bethe equations (3.6) the sum can be replaced by an integral:

$$mL \sinh \theta_i + \int d\theta' \delta(\theta_i - \theta') \rho(\theta') = 2\pi n_i. \quad (3.18)$$

Now, if we subtract the equation for  $i - 1$  and divide by  $\theta_i - \theta_{i-1}$ , we find

$$mL \frac{\sinh \theta_i - \sinh \theta_{i-1}}{\theta_i - \theta_{i-1}} + \int d\theta' \rho^{(p)}(\theta') \frac{\delta(\theta_i - \theta') - \delta(\theta_{i-1} - \theta')}{\theta - \theta'} = 2\pi \frac{n_i - n_{i-1}}{\theta_i - \theta_{i-1}}. \quad (3.19)$$

By comparing with (3.17) and taking derivatives, this leads to the integral equation

$$mL \cosh \theta + (\varphi * \rho^{(p)})(\theta) = 2\pi\rho(\theta) \quad (3.20)$$

where

$$\varphi(\theta) = \frac{d\delta(\theta)}{d\theta} = -i\frac{dS(\theta)}{d\theta}, \quad (\varphi * \rho^{(p)})(\theta) = \int d\theta' \rho^{(p)}(\theta')\varphi(\theta - \theta'). \quad (3.21)$$

The thermodynamic quantities can be obtained by minimizing the free energy

$$F = E - TS \quad (3.22)$$

where  $E$  is given by the equation (3.17) and the temperature corresponds to the inverse of the circumference  $T = 1/R$ . The entropy can be calculated by considering the number of different distributions of particles among levels. For the fermionic particles the number of configurations corresponds to

$$\frac{(N_i)!}{(n_i)!(N_i - n_i)!} \quad (3.23)$$

and for the bosonic case

$$\frac{(N_i + n_i - 1)!}{(n_i)!(N_i - 1)!} \quad (3.24)$$

where  $N_i \sim \rho(\theta_i)\Delta\theta_i$  and  $n_i \sim \rho^{(p)}(\theta_i)\Delta\theta_i$ . In the thermodynamic limit the entropy is calculated by taking the number of configurations, in fermionic case this leads to

$$S_{\mathcal{F}} = \int d\theta [\rho \log \rho - \rho^{(p)} \log \rho^{(p)} - (\rho - \rho^{(p)}) \log(\rho - \rho^{(p)})] \quad (3.25)$$

and for bosons the entropy is

$$S_{\mathcal{B}} = \int d\theta [-\rho \log \rho - \rho^{(p)} \log \rho^{(p)} + (\rho + \rho^{(p)}) \log(\rho + \rho^{(p)})]. \quad (3.26)$$

The free energy should be minimize under the constraint of Bethe equation (3.20), so the function to minimize take the form

$$\begin{aligned} \mathcal{F}[\rho, \rho^{(p)}, \lambda] = & \int d\theta [\rho^{(p)} mR \cosh \theta + \rho \log \rho - \rho^{(p)} \log \rho^{(p)} - (\rho - \rho^{(p)}) \log(\rho - \rho^{(p)}) \\ & + \lambda(2\pi - mL \cosh \theta - (\varphi * \rho^{(p)})(\theta))]. \end{aligned} \quad (3.27)$$

The functional derivatives are

$$\frac{\delta \mathcal{F}[\rho, \rho^{(p)}, \lambda]}{\delta \rho} = \int d\theta [\log \frac{\rho - \rho^{(p)}}{\rho} + 2\pi\lambda] = 0 \quad (3.28)$$

$$\frac{\delta \mathcal{F}[\rho, \rho^{(p)}, \lambda]}{\delta \rho^{(p)}} = \int d\theta [mR \cosh \theta - \log \frac{\rho - \rho^{(p)}}{\rho^{(p)}} - (\phi * \lambda)(\theta)] = 0 \quad (3.29)$$

$$\frac{\delta \mathcal{F}[\rho, \rho^{(p)}, \lambda]}{\delta \lambda} = \int d\theta [2\pi\rho - mL \cosh \theta - (\varphi * \rho^{(p)})(\theta)] = 0 \quad (3.30)$$

Now, if we solve for  $\lambda$  and put (3.28) in (3.29) we obtain

$$\log \frac{\rho - \rho^{(p)}}{\rho^{(p)}} = mR \cosh \theta - \frac{1}{2\pi} (\varphi * \log \frac{\rho}{\rho - \rho^{(p)}})(\theta). \quad (3.31)$$

We can rewrite this equation using a new variable  $\epsilon$ , which is named ‘‘pseudo-energy’’

$$e^\epsilon(\theta) = \frac{\rho^{(p)}(\theta)}{\rho(\theta) - \rho^{(p)}(\theta)} \quad (3.32)$$

so, equation (3.31) becomes

$$\epsilon(\theta) = mR \cosh \theta - \frac{1}{2\pi} (\varphi * \log(1 + e^{-\epsilon}))(\theta). \quad (3.33)$$

This is a non linear integral equation called *Thermodynamic Bethe Ansatz Equation*. Using the equation (3.12) it is possible to obtain a relation for the energy in terms of pseudo-energy

$$E(R) = \frac{RF(\rho, \rho^{(p)})}{L} = \frac{1}{L} \int d\theta [Rm\rho^{(p)} \cosh \theta - \rho \log \rho + \rho^{(p)} \log \rho^{(p)} + (\rho - \rho^{(p)}) \log(\rho - \rho^{(p)})] \quad (3.34)$$

using (3.30) and (3.32) this equation takes the form

$$E(R) = -m \int \frac{d\theta}{2\pi} L(\theta) \cosh \theta \quad (3.35)$$

where we define  $L$ -function as

$$L(\theta) = \log(1 + e^{-\epsilon(\theta)}). \quad (3.36)$$

The same calculation can be done for the bosonic case, where the TBA equation assume the form

$$\epsilon(\theta) = mR \cosh \theta + \frac{1}{2\pi} (\varphi * \log(1 - e^{-\epsilon}))(\theta). \quad (3.37)$$

The bosonic pseudo-energy is defined as

$$e(\theta)^{-\epsilon} = \frac{\rho^{(p)}(\theta)}{\rho(\theta) + \rho^{(p)}(\theta)}. \quad (3.38)$$

All thermodynamic quantities can be calculated solving the TBA equations. However, the TBA equations are usually hard to solve, one can extract a lot of information from them even without solving these equations explicitly. For example, one can evaluate the UV and IR limits. The explicit solution can be obtained with numerical methods and arbitrary precision can be reached, in this sense the solution is exact.

### 3.1.3 UV and IR limits

We want to evaluate the fermionic TBA equation in the high-temperature limit (UV limit). The solution in this limit is also called kink solution. So, consider a TBA equation

$$\epsilon(\theta) = r \cosh \theta - \frac{1}{2\pi}(\varphi * L)(\theta) \quad (3.39)$$

where  $r$  is the dimensionless scaling length. Reach the UV limit means take  $r \rightarrow 0$ . In this regime the solution presents a constant region which is denoted with the name *plateau region*. The plateau can be estimated to be in the interval  $[-\log(2/r), \log(2/r)]$ .

Let us introduce the finite-size scaling function

$$c(r) = \frac{3r}{\pi^2} \int d\theta L(\theta) \cosh(\theta). \quad (3.40)$$

Now we proceed with the analytic study of the kink solution. Note that  $\epsilon(\theta)$  and  $L(\theta)$  are even functions so, we can consider only the right-side part multiplied by 2. In fact, if we perform a shift of the rapidity

$$\epsilon_{kink}(\theta) = \epsilon\left(\theta + \log\left(\frac{2}{r}\right)\right), \quad L_{kink}(\theta) = L\left(\theta + \log\left(\frac{2}{r}\right)\right) \quad (3.41)$$

the TBA becomes

$$\epsilon_{kink}(\theta) = e^\theta + \frac{1}{2\pi}(\varphi * L)(\theta) \quad (3.42)$$

and the Casimir energy reads

$$\lim_{r \rightarrow 0} c(r) = c_{eff} = \frac{3}{\pi^2} \int d\theta L_{kink}(\theta) e^\theta. \quad (3.43)$$

This integral can be recast in more suitable form

$$c_{eff} = \frac{6}{\pi^2} \mathcal{I} \quad (3.44)$$

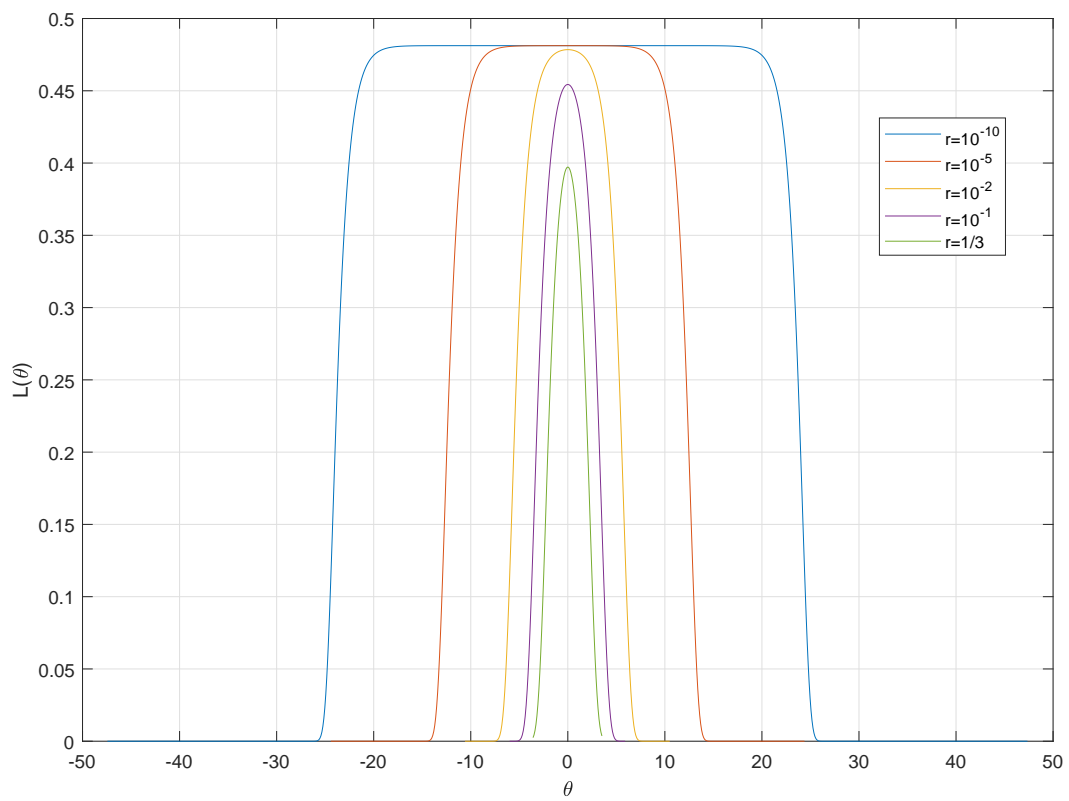

Figure 3.3:  $L$ -functions of 3-states Potts model.



where

$$\mathcal{I} = \frac{1}{2} \int_{-\infty}^{\infty} d\theta \left[ \log(1 + e^{-\epsilon}) + \frac{\epsilon(\theta)}{1 + e^{\epsilon(\theta)}} \right]. \quad (3.45)$$

If we use the integration variable  $t = 1/(1 - e^{\epsilon(\theta)})$  and we denote with  $L_{\pm}$  the asymptotic values, we obtain

$$\mathcal{I} = \frac{1}{2} \int_{L_-}^{L_+} \left[ \frac{\log(1-t)}{t} + \frac{\log(t)}{1-t} \right] \quad (3.46)$$

where

$$L_{\pm} = \frac{1}{1 + e^{\epsilon(\pm\infty)}}. \quad (3.47)$$

This solution can be rewritten in terms of *Rogers Dilogarithm function*:

$$\mathcal{L} = -\frac{1}{2} \int_0^x dt \left[ \frac{\log(1-t)}{t} + \frac{\log(t)}{1-t} \right], \quad 0 < x < 1. \quad (3.48)$$

We see that the equation (3.46) can be written as a sum of two Rogers dilogarithms

$$\mathcal{I} = \mathcal{L}(L_-) - \mathcal{L}(L_+). \quad (3.49)$$

We can go to the IR limit taking  $r \rightarrow \infty$  in the equation (3.39). The TBA equation becomes

$$\epsilon(\theta) = r \cosh(\theta) + O(e^{-r}). \quad (3.50)$$

If we put this into the scaling-function (3.40) we can produce the asymptotic low-temperature expansion

$$c(r) = \frac{6r}{\pi} (C_1(r) + C_2(r) + \dots) \quad (3.51)$$

where  $C_n(r) \sim \exp(-r)$ . For example,  $C_1(r)$  reads,

$$C_1(r) = \frac{1}{2\pi} \int d\theta \cosh \theta e^{-r \cosh \theta} = \frac{1}{\pi} K_1(r) \quad (3.52)$$

where  $K_1(r)$  is the modified Bessel function. For  $r \rightarrow \infty$  the behavior of the system is that of a free theory.

### 3.1.4 Universal TBA's and Y-systems

There is a class of systems, which is perturbation of CFT, related to the A,D and E affine Lie algebras. These theories may be formulated in terms of a very elegant TBA equations which highlight a common structure of all these theories. These systems are described by a set of non linear equations for pseudo-energies  $\epsilon_a$  where  $a = 1, 2, \dots$  is

the number of particles. The number of particles is equal to the rank  $r$  of the algebra  $\mathcal{A}$ . Consider the TBA equations in the form

$$\epsilon_a(\theta) = \nu_a(\theta) - \frac{1}{2\pi} \sum_a (\varphi_{ab} * L_b)(\theta) \quad (3.53)$$

where to each particle is associated a driving term

$$\nu_a(\theta) = m_a R \cosh(\theta). \quad (3.54)$$

These equations can be rewritten into a *universal form*. The fundamental identity in this formulation is given by

$$\left(\delta_{ab} - \frac{1}{2\pi} \varphi(k)\right)^{-1} = \delta_{ab} - \frac{1}{2 \cosh(k/h)} I_{ab} \quad (3.55)$$

where appears the Fourier transform

$$\varphi_{ab}(k) = \int_{-\infty}^{\infty} d\theta \varphi_{ab}(\theta) \exp(ik\theta). \quad (3.56)$$

The quantity  $I_{ab}$  is the incidence matrix of the Dynking diagram of the corresponding algebra  $\mathcal{A}$ . In fact, we can associate to each node of the Dynking diagram pseudo-energies of a given model. We have to consider other objects derived from groups theory, namely the dual Coxeter number  $h$  and the Coxeter adjacency matrix  $G = 2 - C$ .

Applying the (3.55) to the (3.53) yields to the *TBA universal form*

$$\epsilon_a(\theta) = \nu_a(\theta) - \frac{1}{2\pi} \sum_b G_{ab} (\varphi_h * (\nu_b - \Lambda_b))(\theta) \quad (3.57)$$

where  $\Lambda = \log(1 + e^{\epsilon_a})$  and  $\varphi_h$  is the universal kernel

$$\varphi_h(\theta) = \frac{h}{2 \cosh \frac{h\theta}{2}}. \quad (3.58)$$

Note that the kernel depends only on the Coxeter number  $h$  and the coupling information is encoded in the adjacency matrix  $G_{ab}$ .

Another way of writing the TBA equations is to express them in the set of functional equations, the so-called *Y-systems* [28, 29]. This recasting must be defined very carefully and it involves the analytical continuation of the equation (3.57) to the complex values. One can check that solutions of the equation (3.57) are also solution of the Y-system, defined as

$$Y_a(\theta + i\frac{\pi}{h}) Y_a(\theta - i\frac{\pi}{h}) = \prod_{b=1}^r [1 + Y_b(\theta)]^{I_{ab}} \quad (3.59)$$

where  $Y_a(\theta) = \exp(\epsilon_a(\theta))$ . Y-systems are completely independent of the driving term and it involve only informations of the algebras. For the driving term holds the relation

$$\nu_a(\theta + i\frac{\pi}{h}) + \nu_a(\theta - i\frac{\pi}{h}) = \sum_b l_{ab}\nu_b(\theta). \quad (3.60)$$

Y-systems have the following periodic properties

$$\begin{aligned} Y_a(\theta + i\pi\frac{h+2}{h}) &= Y_{n-a+1}(\theta), \quad A_n \text{ series} \\ Y_a(\theta + i\pi\frac{h+2}{h}) &= Y_a(\theta), \quad D_n \text{ and } E_n \text{ series.} \end{aligned} \quad (3.61)$$

One of the consequences of the periodicity is that the solutions are entire functions of  $\theta$  and Y-functions admit the following Laurent expansion

$$Y_a(\theta) = \sum_{n=-\infty}^{\infty} Y_a^n t^n \quad (3.62)$$

where  $t = \exp([2h/(h+2)]\theta)$ .

The periodicity property is also related to the conformal dimension of the perturbed field via the relation

$$\Delta = 1 - \frac{h}{h+2}. \quad (3.63)$$

In the high temperature limit ( $r \rightarrow 0$ ) the  $L(\theta)$ -functions acquires the form of plateau in the region  $-\log(1/mR) \ll \theta \ll \log(1/mR)$  and the Y-system can be expressed as

$$\lim_{r \rightarrow 0} Y_a(\theta) = y_a(\theta) \quad (3.64)$$

where  $y_a(\theta)$  satisfy the transcendental equation

$$y_a = \prod_b (1 + \frac{1}{y_a})^{N_{ab}}, \quad N_{ab} = - \int_{-\infty}^{\infty} \frac{d\theta}{2\pi} \varphi_{ab}(\theta). \quad (3.65)$$

This quantity can be employed to evaluate the central charge of the model

$$c^{eff} = \lim_{r \rightarrow 0} c(r) = \frac{6}{\pi^2} \sum_a L(\frac{1}{1+y_a}). \quad (3.66)$$

Summarizing, the Y-system is extremely powerful since it encodes a lot of information about the model and allows to compute the central charge and the conformal dimension of the theory.

## 3.2 TBA for non-diagonal S-matrices

The TBA techniques discussed so far are developed for models with interactions described by a diagonal S-matrix. In the case of non-diagonal S-matrix the TBA equations are much harder to derive. This is because when we imposing the periodic boundary condition we must know what happens when a particle takes a trip around the world. If the S-matrix is non-diagonal, the scattering between two particle changes the state of the particles and we have products of non-diagonal matrices which computation correspond to the diagonalization of the transfer matrix. In order to understand how to proceed we need to use some results of *the Algebraic Bethe Ansatz*.

In this section we present the computation of TBA for theories defined as the perturbation of coset  $(A_{m-1})_k \times (A_{m-1})_l / (A_{m-1})_{k+l}$  by the relevant operator  $\phi_{1,1,adj}$ . The case of minimal models ( $m = 2, k > 1, l = 1$ ) will be particularly emphasized. This calculation has been proposed by T. J. Hollowood in [32], in the paper [33] the generalization to simple Lie algebras  $B_{m-1}, C_{m-1}, D_{m-1}$  is described. In the article [34] Al. B. Zamolodchikov conjectured the TBA for the infinite series of minimal models. The conformal dimension of the perturbation operator is

$$\Delta = \frac{k+l}{k+l+g} \quad (3.67)$$

where  $g$  is the dual coxeter number of algebra  $A_{m-1}$ . In the case of minimal models  $\phi_{1,1,adj}$  is the well known  $\Phi_{31}$  relevant operator.

The S-matrix for this perturbed conformal field theory is conjectured to have the following form

$$S_{(k,l)}^{ab}(\theta) = X^{ab}(\theta) S_{(k)}^{ab}(\theta) \otimes S_{(l)}^{ab}(\theta) \quad (3.68)$$

where  $S_{(k)}^{ab}(\theta)$  is a trigonometric S-matrix with elements proportional to Boltzmann weights of *Restricted Solid-on-Solid* (RSOS) model. This S-matrix describes the scattering between  $a = 1, 2, \dots, m-1$  fundamental representations of  $A_{m-1}$  algebra. The parameter  $k$  corresponds to the restriction of the RSOS model. The prefactor  $X^{ab}(\theta)$  is a CDD factor which generally has the structure:

$$X^{ab}(\theta) = \prod_{\substack{j=|a-b|+1 \\ \text{step } 2}}^{b+a-1} \frac{\sinh(\frac{1}{2}\theta + i\pi \frac{j+1}{2m}) \sinh(\frac{1}{2}\theta + i\pi \frac{j-1}{2m})}{\sinh(\frac{1}{2}\theta - i\pi \frac{j+1}{2m}) \sinh(\frac{1}{2}\theta - i\pi \frac{j-1}{2m})} \quad (3.69)$$

or in integral form

$$X^{ab}(\theta) = \exp\left(i\pi\delta_{ab} - \int_{-\infty}^{\infty} \frac{dx}{x} \exp\left(\frac{im\theta x}{\pi}\right) (\hat{A}_{ab}^m(x) - \delta_{ab})\right), \quad (3.70)$$

with the kernels defined as follows

$$\hat{A}_{ab}^{(m)}(x) = \frac{2 \sinh(ax) \sinh[(m-b)] \cosh(x)}{\sinh(mx) \sinh(x)}, \quad b \geq a. \quad (3.71)$$

Note that in the case of minimal models

$$S_{(l=1)}^{ab}(\theta) = 1 \quad \text{and} \quad X^{ab}(\theta) = -1 \quad (3.72)$$

so the equation (3.68) become

$$S_{(k,l)}^{ab}(\theta) = -S_{(k)}^{ab}(\theta). \quad (3.73)$$

### 3.2.1 Trigonometric S-matrix

The derivation of the Trigonometric S-matrix for  $A_{m-1}$  algebras can be found in [35]. In this section we will present a brief review. The elements of the S-matrix associated to the Lie algebra  $A_{m-1}$  are defined from the Boltzmann weights of the RSOS-model. A RSOS-model is defined on a lattice  $\mathcal{L}$ . On each vertex of the lattice is defined a local height  $a, b, c, \dots \in \Sigma$ . The difference between two vertexes must belong to some specified set  $\Omega$ . The local heights (or vacua) are related to representations of the Lie algebra  $A_{m-1}$ . The defining representation of the  $A_{m-1}$  is the vector representation. From these representations one can get  $S_{(k)}^{ab}(\theta)$  by using fusion procedures. The set  $\Omega$  takes values from the set of weights of the vector representations:

$$\Omega = \{e_1 - \bar{e}, \dots, e_{n+1} - \bar{e}\}, \quad \bar{e} = \frac{\sum_{i=1}^{n+1} e_i}{n+1}. \quad (3.74)$$

In the vector representation, a state (kink)  $K_{ab}(\theta)$  connects two vacua  $a, b$  (or local heights of the statistical lattice) and  $\theta$  is the rapidity of the kink. The scattering between two kinks are defined as

$$|K_{ac}(\theta_1) + K_{cd}(\theta_2)\rangle \rightarrow \sum_b \bar{S}_u \begin{pmatrix} a & b \\ c & d \end{pmatrix} |K_{ab}(\theta_1) + K_{bd}(\theta_2)\rangle. \quad (3.75)$$

The S-matrix of kink-kink scattering is proportional to the Boltzmann weight  $W \begin{pmatrix} a & b \\ c & d \end{pmatrix} |u\rangle$  of the RSOS lattice model. The Boltzmann weights depend on the spectral parameter  $u \in \mathbb{C}$  and they are the solution of the Yang-Baxter equation (or star-triangle relation)

$$\begin{aligned} \sum_f W \begin{pmatrix} g & f \\ d & e \end{pmatrix} |u\rangle W \begin{pmatrix} b & c \\ f & e \end{pmatrix} |v\rangle W \begin{pmatrix} a & b \\ g & f \end{pmatrix} |u+v\rangle = \\ \sum_f W \begin{pmatrix} a & b \\ f & c \end{pmatrix} |u\rangle W \begin{pmatrix} a & f \\ g & d \end{pmatrix} |v\rangle W \begin{pmatrix} f & c \\ d & e \end{pmatrix} |u+v\rangle \end{aligned} \quad (3.76)$$

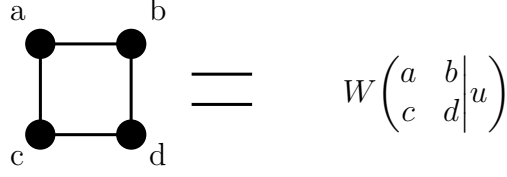

Figure 3.4: Equivalence between statistical lattice and Boltzmann weight.

with  $b - a, d - c, d - b, c - a \in \Omega$ . A set of non-zero solutions is

$$\begin{aligned}
 W\left(\begin{array}{cc|c} a & a + \mu & u \\ a + \mu & a + 2\mu & \end{array}\right) &= \frac{\sin(\omega - \lambda u)}{\sin(\omega)}, \\
 W\left(\begin{array}{cc|c} a & a + \mu & u \\ a + \mu & a + \mu + \nu & \end{array}\right) &= \frac{\sin(a_{\mu\nu} + \lambda u)}{\sin(a_{\mu\nu})}, \\
 W\left(\begin{array}{cc|c} a & a + \nu & u \\ a + \mu & a + \mu + \nu & \end{array}\right) &= \frac{\sin(\lambda u)}{\sin(\omega)} \left( \frac{\sin(a_{\mu\nu} + \omega) \sin(a_{\mu\nu} - \omega)}{\sin^2(a_{\mu\nu})} \right)^{\frac{1}{2}},
 \end{aligned} \tag{3.77}$$

where  $\mu \neq \nu$  and  $\mu, \nu \in \Omega$ . The other parameters are

$$\begin{aligned}
 a_{\mu\nu} &= \omega(a + \rho) \cdot (\mu - \nu), \\
 \rho &= \sum_i \omega_i,
 \end{aligned} \tag{3.78}$$

where  $\omega_i$  are fundamental weights of the algebra. The solution (3.76) is the unrestricted solution, where local heights may take any value in the set of weights of the algebra. The restriction can be introduced by selecting particular values of  $\omega$ . The parameter  $\omega$  is related to the deformation parameter of the group

$$\omega = \frac{\pi}{(g + k)}, \quad k = 1, 2, 3, \dots, \tag{3.79}$$

with  $g$  the dual coxeter number of the algebra and  $k$  the level. The restriction condition is

$$a \cdot \theta \leq k, \tag{3.80}$$

where  $\theta$  represent the highest root of the algebra.

The set of solutions of Yang-Baxter equation (3.76) must satisfy the postulates of the S-matrix theory, namely: unitarity, crossing symmetry and crossing unitarity. The conjectured  $S$ -matrix which describes the process (3.75) has the following form

$$\bar{S}_u \left( \begin{array}{cc} a & b \\ c & d \end{array} \right) = Y(u) W \left( \begin{array}{cc|c} a & b & u \\ c & d & \end{array} \right) \left( \frac{G_a G_d}{G_b G_c} \right)^{\frac{f(u)}{2}}, \tag{3.81}$$

with  $u = \frac{\theta_2 - \theta_1}{i\pi}$  the difference between kinks rapidities. The minimal solution for  $Y(u)$  are deduced from the crossing and unitary requirements

$$Y_{mk}(u) = \exp \left[ \int_0^\infty \frac{dx}{x} \frac{2 \sinh(\frac{mux}{2})}{\sinh[(k+m)x] \sinh(mx)} \right. \\ \left. \times \left( \cosh(kx) \cosh(\frac{mxu}{2}) - \cosh[(m+k-2)x] \cosh[mx(\frac{u}{2} - 1)] \right) \right]. \quad (3.82)$$

The quantities  $G_a$  are defined as follows

$$G_{a_\mu} = \frac{\sin(\omega(a+\rho) \cdot \mu + \omega)}{\sin(\omega(a+\rho) \cdot \mu)} \prod_{k \neq \pm\mu, 0} \frac{\sin(a_{\mu k} + \omega)}{\sin(a_{\mu k})} \quad \mu \neq 0, \quad (3.83)$$

$$G_{a_0} = 1.$$

The S-matrix  $\bar{S}$  doesn't contain poles. The poles can be added by multiplying (3.81) by a CDD factor which can be computed by considering the spectral decomposition of the R-matrix and it reads

$$X(u) = \frac{\sin(\frac{\pi u}{2} + \frac{\pi}{m})}{\sin(\frac{\pi u}{2} - \frac{\pi}{m})}. \quad (3.84)$$

The minimal S-matrix can be obtained from the bootstrap principle and has the form

$$\bar{S}_{(k)}^{ab} = Y^{ab}(u) R^{ab}(u). \quad (3.85)$$

The R-matrix is given by

$$R^{ab}(u) = Z^{ab}(u) \sum_{k=0}^{\min(m-b,a)} (-1)^{k+1} \rho_k^{ab}(u) \mathbb{P}_{\lambda_{b+k} + \lambda_{b-k}}, \quad (3.86)$$

where  $\lambda_i$  are fundamental weights and

$$\rho_k^{ab}(u) = \sum_{p=1}^k \{2p + b - a\} \sum_{p=k+1}^{\min(m-b,a)} \{-2p - b + a\}, \quad (3.87)$$

$$Z^{ab}(u) = \prod_{j^1}^a \prod_{k=1}^{b-1} \{2j + 2k - a - b\} \prod_{p=\min(m-b,a)+1}^a \{-2p - b + a\}$$

with  $\lambda_0 = \lambda_m = 0$  and

$$\{x\} = \frac{\sin(\frac{\omega x}{2} + \lambda u)}{\sin(\omega)}. \quad (3.88)$$

The S-matrix (3.85) has no poles in physical strip, the bootstrap consistent S-matrix has the following form

$$S_k^{ab}(\theta) = X^{ab}(\theta) S_k^{ab}(\theta) \quad (3.89)$$

where  $X^{ab}(\theta)$  is given in (3.70).

The mass spectrum of the algebra  $A_{m-1}$  is

$$m_a = M \sin \frac{\pi a}{m}, \quad a = 1, 2, 3, \dots, m-1. \quad (3.90)$$

In the case of minimal models there is only one massive particle and  $m = 1$ .

### 3.2.2 Thermodynamics

The derivation of TBA is similar to the diagonal case. We are describing a gas of  $N$  particles. The quantization condition in non-diagonal case reads

$$e^{im_a L \sinh \theta_i} \mathcal{T}(\theta_i | \theta_1, \dots, \theta_{i-1}, \theta_{i+1}, \dots, \theta_N) = 1 \quad (3.91)$$

where  $\mathcal{T}$  is the transfer matrix constructed as follows

$$\mathcal{M}^a(\theta | \theta_1, \dots, \theta_{i-1}, \theta_{i+1}, \dots, \theta_N) = \prod_{\substack{k=1 \\ i \neq j}} S^{aa_k}(\theta - \theta_k). \quad (3.92)$$

The transfer matrix is obtained by taking the trace over the space of auxiliary particle

$$\mathcal{T}(\theta_i | \theta_1, \dots, \theta_{i-1}, \theta_{i+1}, \dots, \theta_N) = \text{Tr}_0 \mathcal{M}^a(\theta | \theta_1, \dots, \theta_{i-1}, \theta_{i+1}, \dots, \theta_N). \quad (3.93)$$

where  $a$  is the auxiliary particle with velocity  $\theta$ . The equation (3.91) means that we are putting an auxiliary particle  $a$  on a circle with a gas of  $N$  particles and the auxiliary particle take a trip through them all. The diagonalization of the non-diagonal transfer matrix leads to appearing of the magnonic excitations which are described by the *Bethe ansatz equation* (BAE). These new excitations (or particles), as we will see, appear in TBA equations with  $m = 0$ . The transfer matrix have a set of eigenvectors  $\psi^i(\theta_1, \dots, \theta_N)$  with eigenvalues  $\lambda^i(\theta | \theta_1, \dots, \theta_N)$  which usually are hard to compute. In the thermodynamic limit, when the number of particles and the length of the system are going to infinity, only the dominant eigenvalue contribute to the thermodynamics. The conjectured expression for leading term is

$$\begin{aligned} & \prod_{\substack{i=1 \\ i \neq j}}^N X^{a_j a_i}(\theta_j - \theta_i) \sigma_k^{a_j a_i}(\theta_j - \theta_i) \sigma_l^{a_j a_i}(\theta_j - \theta_i) \times \\ & \times \prod_{\alpha=1}^{M_{a_j}^k} \frac{\sinh[(\frac{m}{2(m+k)})(\theta_j - u_\alpha^{a_j} + i\frac{\pi}{m})]}{\sinh[(\frac{m}{2(m+k)})(\theta_j - u_\alpha^{a_j} - i\frac{\pi}{m})]} \prod_{\alpha=1}^{M_{a_j}^l} \frac{\sinh[(\frac{m}{2(m+l)})(\theta_j - v_\alpha^{a_j} + i\frac{\pi}{m})]}{\sinh[(\frac{m}{2(m+l)})(\theta_j - v_\alpha^{a_j} - i\frac{\pi}{m})]}, \end{aligned} \quad (3.94)$$



the parameters  $u_\alpha$  and  $v_\alpha$  satisfy the Bethe ansatz equations:

$$\prod_{j=1}^N \frac{\sinh[(\frac{m}{2(m+k)})(u_\alpha^{(a)} - \theta_j + i\frac{\pi}{m}\omega_{a_j} \cdot \alpha_a)]}{\sinh[(\frac{m}{2(m+k)})(u_\alpha^{(a)} - \theta_j - i\frac{\pi}{m}\omega_{a_j} \cdot \alpha_a)]} = \Omega_\alpha^{(a)} \prod_{c=1}^{m-1} \prod_{\beta=1}^{M_c^{(k)}} \frac{\sinh[(\frac{m}{2(m+k)})(u_\alpha^{(a)} - u_\beta^{(c)} + i\frac{\pi}{m}\alpha_a \cdot \alpha_b)]}{\sinh[(\frac{m}{2(m+k)})(u_\alpha^{(a)} - u_\beta^{(c)} - i\frac{\pi}{m}\alpha_a \cdot \alpha_b)]} \quad (3.95)$$

where  $\Omega_\alpha^{(a)}$  is a constant which do not give any contribute in the thermodynamic limit.  $M_c$  is the set of solutions. The  $\alpha_a$  and  $\omega_{a_j}$  are simple roots and fundamental weights of  $A_{m-1}$ . They satisfy

$$\alpha_a \cdot \omega_b = \delta_{ab}, \quad C_{ab} = \frac{2\alpha_a \alpha_b}{\alpha_a \alpha_a} \quad (3.96)$$

where  $C_{ab}$  is the Cartan matrix of the  $A_{m-1}$  algebra.

The next step is to take the thermodynamic limit ( $T \rightarrow \infty$ ,  $L \rightarrow \infty$ ). The number of particles becomes infinite and they may be described more appropriately by densities. We define

$$\begin{aligned} \rho^{a(p)}(\theta) & \quad \text{densities of particles,} \\ \bar{\rho}^a(\theta) & \quad \text{densities of holes,} \\ \rho^a(\theta) = \rho^{a(p)}(\theta) + \bar{\rho}^a(\theta) & \quad \text{densities of states.} \end{aligned}$$

The solutions of (3.95), for a set of numbers  $u_\alpha$ , are organized in the strings of the form

$$u^{(a)} = u_c^{(a)} + i\frac{\pi}{m}(n+1-2j) \quad j = 1, 2, \dots, n, \quad (3.97)$$

where  $u_c^{(a)} \in \mathbb{R}$  is the center of string of length  $n$ . The possible values of length of a string are  $n = 1, \dots, k$ . Similarly, the same formulation holds for  $v_\alpha^{(a)}$ , where the possible values of the length of a string are  $n = 1, \dots, l$ . This conjecture, in literature, is known with the name *string hypothesis*. The center of strings, in thermodynamic limit, are also described by densities. We will use the following notation

$$\begin{aligned} \mu^{a(p)}(\theta) & \quad \nu^{a(p)}(\theta) & \quad \text{densities of centers of strings,} \\ \bar{\mu}^a(\theta) & \quad \bar{\nu}^a(\theta) & \quad \text{densities of holes of centers of strings,} \\ \mu^a(\theta) = \mu^{a(p)}(\theta) + \bar{\mu}^a(\theta) & \quad \nu^a(\theta) = \nu^{a(p)}(\theta) + \bar{\nu}^a(\theta) & \quad \text{densities of states of centers of strings} \end{aligned}$$

where with the letter  $\mu$  we refer to the center of strings generated by the numbers  $u_\alpha$  and with  $\nu$  to densities generated by  $v_\alpha$ .

Proceeding of taking log of equations (3.94) and differentiate with respect to  $\theta_j$  produce the following non linear integral equation

$$\rho^a(\theta) = \frac{m_a}{2\pi} \cosh(\theta) + \sum_{b=1}^{m-1} (Y^{ab} * \rho^{b(p)})(\theta) - \sum_{n=1}^k (a_n^{m+k} * \mu_n^{a(p)})(\theta) - \sum_{n=1}^l (a_n^{m+l} * \nu_n^{a(p)})(\theta). \quad (3.98)$$

We can rewrite the prefactor  $Y^{ab}(\theta)$  as follows

$$Y^{ab}(\theta) = \frac{1}{2\pi i} \frac{d}{d\theta} \log \left( X^{ab}(\theta) \sigma_k^{ab}(\theta) \sigma_l^{ab}(\theta) \right) = \quad (3.99)$$

where

$$\begin{aligned} \frac{1}{2\pi i} \frac{d}{d\theta} \left[ \log \left( X^{ab}(\theta) \right) \right] = \\ - \frac{m}{2\pi^2} \int_{-\infty}^{\infty} dx \exp \left( \frac{im\theta x}{\pi} \right) \left[ \frac{2 \cosh(x) \sinh(ax) \sinh[(m-b)x]}{\sinh(x) \sinh(mx)} - \delta_{ab} \right] \end{aligned} \quad (3.100)$$

and

$$\begin{aligned} \frac{1}{2\pi i} \frac{d}{d\theta} \left[ \log \left( \sigma_k^{ab}(\theta) \sigma_l^{ab}(\theta) \right) \right] = \\ \frac{m}{2\pi^2} \int_{-\infty}^{\infty} dx \exp \left( \frac{im\theta x}{\pi} \right) \left[ \frac{2 \cosh(x) \sinh(ax) \sinh[(m-b)x]}{\sinh(x) \sinh(mx)} - \right. \\ \left. \frac{\sinh[(2m+k+l)x] \sinh(ax) \sinh[(m-b)x]}{\sinh[(m+k)x] \sinh[(m+l)x] \sinh(mx)} \right]. \end{aligned} \quad (3.101)$$

So, the equation (3.99) becomes

$$\begin{aligned} Y^{ab}(\theta) = \delta(\theta) \delta_{ab} - \\ \frac{m}{2\pi^2} \int_{-\infty}^{\infty} dx \exp \left( \frac{im\theta x}{\pi} \right) \frac{\sinh[(2m+k+l)x] \sinh(ax) \sinh[(m-b)x]}{\sinh[(m+k)x] \sinh[(m+l)x] \sinh(mx)} = \\ \delta(\theta) \delta_{ab} - \frac{m}{2\pi^2} \int_{-\infty}^{\infty} dx \exp \left( \frac{im\theta x}{\pi} \right) \hat{A}_{ab}^{(m)}(x) (\hat{A}_{m+l, m+l}^{(2m+k+l)})^{-1}(x). \end{aligned} \quad (3.102)$$

$$\begin{aligned} a_n^{(m+k)}(\theta) = \frac{1}{2\pi i} \frac{d}{d\theta} \sum_{j=1}^n \log \left( \frac{\sinh \left[ \frac{m}{2(m+k)} \left( \theta - i \frac{\pi}{m} (n+2-2j) \right) \right]}{\sinh \left[ \frac{m}{2(m+k)} \left( \theta - i \frac{\pi}{m} (n-2j) \right) \right]} \right) = \\ \frac{1}{2\pi i} \frac{d}{d\theta} \sum_{j=1}^n \log \left( \frac{\sinh \left[ \frac{m}{2(m+k)} \left( \theta - i \frac{\pi}{m} (n+2-2j) \right) \right]}{\sinh \left[ \frac{m}{2(m+k)} \left( \theta + i \frac{\pi}{m} (n+2-2j) \right) \right]} \right). \end{aligned} \quad (3.103)$$

In the last equality we are used the fact that the sum is invariant under the shifting of denominator  $\theta \rightarrow \theta + i\frac{\pi}{m}(2n+2-4j)$ . In the integral representation the equation (3.103) reads

$$a_n^{(m+k)}(\theta) = \frac{m}{2\pi^2} \int_{-\infty}^{\infty} \exp\left(\frac{im\theta x}{\pi}\right) \frac{\sinh[(m+k-n)x]}{\sinh[(m+k)x]} dx. \quad (3.104)$$

Now, if we apply the string hypothesis (3.97) to the Bethe equations (3.95), we obtain

$$\begin{aligned} & \prod_{j=1}^n \prod_{i=1}^N \frac{\sinh\left[\frac{m}{2(m+k)}\left(u_\alpha^{(a)} - \theta_i + \frac{i\pi}{m}(n+1-2j) + \frac{i\pi}{m}(\omega_{\alpha_j} \cdot \alpha_a)\right)\right]}{\sinh\left[\frac{m}{2(m+k)}\left(u_\alpha^{(a)} - \theta_i + \frac{i\pi}{m}(n+1-2j) - \frac{i\pi}{m}(\omega_{\alpha_j} \cdot \alpha_a)\right)\right]} = \\ & \Omega_\alpha^{(a)} \prod_{\beta=1}^{M_{n'}^k} \prod_{n'=1}^k \prod_{j'=1}^{n'} \prod_{j=1}^n \prod_{c=1}^{m-1} \frac{\sinh\left[\frac{m}{2(m+k)}\left(u_\alpha^{(a)} - u_\beta^{(c)} + \frac{i\pi}{m}(n-2j) - \frac{i\pi}{m}(n'-2j') + \frac{i\pi}{m}(\alpha_a \cdot \alpha_b)\right)\right]}{\sinh\left[\frac{m}{2(m+k)}\left(u_\alpha^{(a)} - u_\beta^{(c)} + \frac{i\pi}{m}(n-2j) - \frac{i\pi}{m}(n'-2j') - \frac{i\pi}{m}(\alpha_a \cdot \alpha_b)\right)\right]}. \end{aligned} \quad (3.105)$$

We denote centers of strings by  $u_\alpha$ . Next step is to take the logarithm and the derivative respect  $u_\alpha$ , this yields to the following equation (articles [36] and [37] may clarify this calculation)

$$\begin{aligned} (a_p^{(m+k)} * \rho^{a(p)})(\theta) &= \sum_c^n (A_{pc}^{(m+k)} * K_{ab}^{(m)} * \nu_c^{b(p)})(\theta) + \bar{\nu}^a(\theta), \\ a &= 1, \dots, m-1, \quad p = 1, \dots, k. \end{aligned} \quad (3.106)$$

Similarly, for  $v_\alpha$  we have

$$\begin{aligned} (a_p^{(m+l)} * \rho^{a(p)})(\theta) &= \sum_c^n (A_{pc}^{(m+l)} * K_{ab}^{(m)} * \mu_c^{b(p)})(\theta) + \bar{\mu}^a(\theta), \\ a &= 1, \dots, m-1, \quad p = 1, \dots, l. \end{aligned} \quad (3.107)$$

Before proceeding we pass to the Fourier transform of (3.106), (3.107) and (3.98), defined as

$$f(\theta) = \frac{m}{2\pi^2} \int_{-\infty}^{\infty} dx \exp\left(\frac{im\theta x}{\pi}\right) \hat{f}(x) \quad (3.108)$$

and the inverse is

$$[f(\theta)]^{-1} = \frac{m}{2\pi^2} \int_{-\infty}^{\infty} dx \exp\left(\frac{im\theta x}{\pi}\right) [\hat{f}(x)]^{-1}. \quad (3.109)$$

The convolutions become products and we obtain the following set of equations

$$\bar{\rho}^a = \frac{m_a}{2\pi} \widehat{\cosh}(\theta) - \sum_{b=1}^{m-1} ([\widehat{A}_{m+l, m+l}^{(2m+k+l)}]^{-1} \widehat{A}_{ab}^{(m)} \rho^{b(p)}) - \sum_{n=1}^k (\widehat{a}_n^{(m+k)} \mu_n^{a(p)}) - \sum_{n=1}^l (\widehat{a}_n^{(m+l)} \nu_n^{a(p)}), \quad (3.110)$$

$$\begin{aligned}\widehat{a}_p^{(m+k)} \rho^{a(p)} &= \sum_{c=1}^k \sum_{b=1}^{m-1} \widehat{A}_{pc}^{(m+k)} \widehat{K}_{ab}^{(m)} \nu_c^{b(p)} + \overline{\nu}_p^a, \\ \widehat{a}_p^{(m+l)} \rho^{a(p)} &= \sum_{c=1}^l \sum_{b=1}^{m-1} \widehat{A}_{pc}^{(m+l)} \widehat{K}_{ab}^{(m)} \mu_c^{b(p)} + \overline{\mu}_p^a.\end{aligned}\tag{3.111}$$

We omit the hat on the densities.  $\widehat{K}_{ab}^m$  is the inverse of  $\widehat{A}_{ab}^m$  such that

$$\widehat{K}_{ac}^{(m)} \widehat{A}_{cb}^{(m)} = \delta_{ab}\tag{3.112}$$

and it can be written as

$$\widehat{K}_{ab}^{(m)}(x) = \delta_{ab} - \frac{1}{2 \cosh(x)} (C_{ab}^{(m)} - 2\delta_{ab}) = \delta_{ab} - \frac{1}{2 \cosh(x)} \mathcal{I}_{ab}^{(m)}\tag{3.113}$$

where  $C_{ab}^{(m)}$  and  $\mathcal{I}_{ab}^{(m)}$  are Cartan matrix and incidence matrix of the  $A_{m-1}$  algebra.

It was noticed that not all strings contribute to the thermodynamic in the thermodynamic limit. As a matter of fact, the  $k$ -string and  $l$ -string can be eliminated. This yield to the simplification of (3.110) and (3.111) and can be derived from the following argument: consider the zero model of the first of (3.111)

$$\frac{m}{m+k} \rho^{a(p)}(0) = \frac{m}{m+k} \sum_{c=1}^k \sum_{b=1}^{m-1} c \mu_c^{b(p)}(0) C_{ab} + \overline{\mu}_k^a(0).\tag{3.114}$$

The transfer matrix eigenvalue (3.94) is associated to the representation  $a_{m-1}$  with the highest weight

$$\mu^{(k)} = \sum_{i=1}^N \omega_{a_i} - \sum_{a=1}^n M_a^{(k)} \alpha_a\tag{3.115}$$

where the possible values of  $M_a^{(k)}$  must obey to the constraint coming from the restriction condition  $\mu \cdot \theta \leq k$ . Taking the thermodynamic limit of this equation, we obtain

$$\mu^{(k)} = \sum_{i=1}^N (\rho^{a(p)}(0) \omega_a - \sum_{c=1}^{m-1} c \mu_c^{a(p)}(0) \alpha_a).\tag{3.116}$$

Using the equation (3.114) and  $\sum_{a=1}^{m-1} C_{ba} \omega_a = \omega_b$ , one gets

$$\mu^{(k)} = L \frac{m+k}{m} \sum_{a=1}^{m-1} \overline{\mu}_k^a(0) \omega_a.\tag{3.117}$$

From the constraint condition we see that

$$L \frac{m+k}{m} \sum_{a=1}^{m-1} \overline{\mu}_k^a(0) \omega_a \cdot \theta \leq k\tag{3.118}$$

which if we take  $L \rightarrow \infty$ , have the solution  $\bar{\mu}_k^a(0) = 0$ .

Using this constraint, consider (3.106) for  $n = k$

$$\sum_b^{m-1} \widehat{A}_{kk}^{(m+k)} \widehat{K}_{ab}^{(m)} \mu_k^{b(p)} + \sum_c^{k-1} \sum_b^{m-1} \widehat{A}_{kc}^{(m+k)} \widehat{K}_{ab}^{(m)} = \widehat{a}_n^{(m+k)} \rho^{a(p)} \quad (3.119)$$

which yields to

$$\mu_k^{b(p)} = - \sum_{c=1}^{k-1} [\widehat{A}_{kk}^{(m+k)}]^{-1} \widehat{A}_{ka}^{(m+k)} \mu_c^{b(p)} + [\widehat{A}_{kk}^{(m+k)}]^{-1} \widehat{A}_{ab}^{(m)} a_k^{(m+k)} \rho^{b(p)} \quad (3.120)$$

and similarly for (3.106) we have

$$\nu_l^{b(p)} = - \sum_{c=1}^{l-1} [\widehat{A}_{ll}^{(m+l)}]^{-1} \widehat{A}_{la}^{(m+l)} \nu_c^{b(p)} + [\widehat{A}_{ll}^{(m+l)}]^{-1} \widehat{A}_{ab}^{(m)} a_l^{(m+l)} \rho^{b(p)}. \quad (3.121)$$

Putting (3.120) and (3.121) into (3.110), we obtain

$$\bar{\rho}^a = \frac{m^a}{2\pi} \widehat{\cosh}(\theta) - \sum_{b=1}^{m-1} \widehat{K}_{ll}^{(k+l)} \widehat{A}_{ab}^{(m)} \rho^{b(p)} - \sum_{b=1}^{m-1} \sum_{q=1}^{k-1} \widehat{K}_{kq}^{(k+l)} \widehat{A}_{ab}^{(m)} \nu_q^{b(p)} - \sum_{b=1}^{m-1} \sum_{q=1}^{l-1} \widehat{K}_{lq}^{(k+l)} \widehat{A}_{ab}^{(m)} \nu_q^{b(p)}. \quad (3.122)$$

and doing the same substitutions in (3.111), after some algebra, we obtain

$$\begin{aligned} \bar{\mu}_p^a &= - \sum_{b=1}^{m-1} \widehat{K}_{pk}^{(k+l)} \widehat{A}_{ab}^{(m)} \rho^{b(p)} - \sum_{b=1}^{m-1} \sum_{c=1}^{k-1} \widehat{K}_{pc}^{(k+l)} \widehat{A}_{ab}^{(m)} \mu_c^{b(p)}, \quad p = 1, \dots, k-1, \\ \bar{\nu}_p^a &= - \sum_{b=1}^{m-1} \widehat{K}_{pl}^{(k+l)} \widehat{A}_{ab}^{(m)} \rho^{b(p)} - \sum_{b=1}^{m-1} \sum_{c=1}^{l-1} \widehat{K}_{pc}^{(k+l)} \widehat{A}_{ab}^{(m)} \nu_c^{b(p)}, \quad p = 1, \dots, l-1. \end{aligned} \quad (3.123)$$

In the last equations we exchanged the roles of particles and holes, namely

$$\mu_p^a \leftrightarrow \bar{\mu}_p^a \quad \nu_p^a \leftrightarrow \bar{\nu}_p^a. \quad (3.124)$$

Now, we can proceed with doing the thermodynamics of the system. As for diagonal TBA, we minimize the free energy  $F = E - TS$  under the constraints (3.122) and (3.123). The energy of the system is

$$E = \sum_{a=1}^{m-1} \int_{-\infty}^{\infty} d\theta \rho^{a(p)}(\theta) m_a \cosh(\theta) \quad (3.125)$$

and the entropy resulting from the combinatoric of densities of particles and states, for fermionic system, is

$$\begin{aligned}
S = & \sum_{a=1}^{m-1} \int_{-\infty}^{\infty} d\theta \left[ \rho^a \log \rho^a - \rho^{a(p)} \log \rho^{a(p)} - (\rho^a - \rho^{a(p)}) \log(\rho^a - \rho^{a(p)}) \right] + \\
& \sum_{a=1}^{m-1} \sum_{n=1}^{k-1} \int_{-\infty}^{\infty} d\theta \left[ \mu_n^a \log \mu_n^a - \mu_n^{a(p)} \log \mu_n^{a(p)} - (\mu_n^a - \mu_n^{a(p)}) \log(\mu_n^a - \mu_n^{a(p)}) \right] + \\
& \sum_{a=1}^{m-1} \sum_{n=1}^{l-1} \int_{-\infty}^{\infty} d\theta \left[ \nu_n^a \log \nu_n^a - \nu_n^{a(p)} \log \nu_n^{a(p)} - (\nu_n^a - \nu_n^{a(p)}) \log(\nu_n^a - \nu_n^{a(p)}) \right].
\end{aligned} \tag{3.126}$$

The minimization of the free energy leads to the following set of the TBA equations

$$\begin{aligned}
\epsilon^a(\theta) = & \frac{m_a}{T} \cosh(\theta) + \sum_{b=1}^{m-1} (K_{ll}^{(k+l)} * A_{ab}^{(m)} * L^b)(\theta) \\
& + \sum_{b=1}^{m-1} \sum_{q=1}^{k-1} (K_{kq}^{(k+l)} * A_{ab}^{(m)} * L_q^{b(r)})(\theta) + \sum_{b=1}^{m-1} \sum_{q=1}^{l-1} (K_{lq}^{(k+l)} * A_{ab}^{(m)} * L_q^{b(l)})(\theta) \\
\epsilon_n^{a(r)} = & L_n^{a(r)} + \sum_{b=1}^{m-1} (K_{nk}^{(k+l)} * A_{ab}^{(m)} * L^b)(\theta) + \sum_{b=1}^{m-1} \sum_{q=1}^{k-1} (K_{nq}^{(k+l)} * A_{ab}^{(m)} * L_q^{b(r)}) \\
\epsilon_n^{a(l)} = & L_n^{a(r)} + \sum_{b=1}^{m-1} (K_{nl}^{(k+l)} * A_{ab}^{(m)} * L^b)(\theta) + \sum_{b=1}^{m-1} \sum_{q=1}^{l-1} (K_{nq}^{(k+l)} * A_{ab}^{(m)} * L_q^{b(l)}).
\end{aligned} \tag{3.127}$$

These equations can be represented with Dynkin diagram as in (fig.3.5).

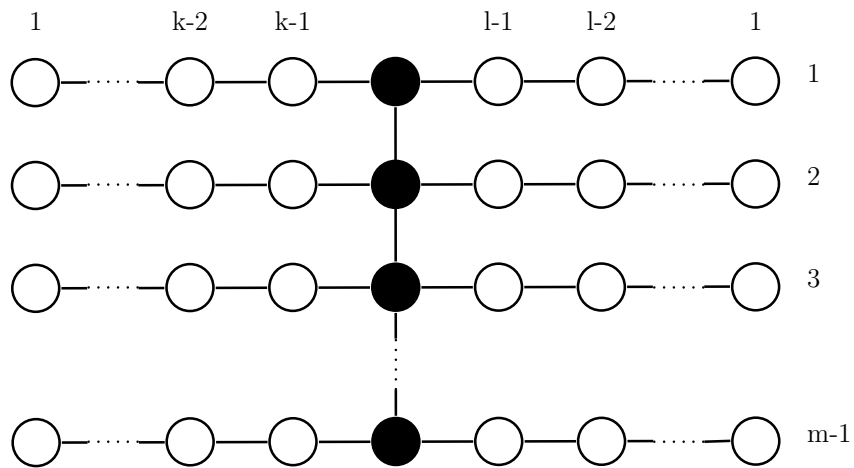

Figure 3.5: Representation of a TBA associated with an algebra  $(A_{m-1})_k \times (A_{m-1})_l / (A_{m-1})_{k+l}$ . The full circles represent the massive pseudoenergies and the empty circles represent magnonic pseudoenergies.

---

## Non-equilibrium Thermodynamic Bethe Ansatz

---

In this chapter, armed with integrability tools discussed in the second chapter, we continue the treatment of non-equilibrium systems described in the first chapter. In particular, we study the solution of the partition problem and the generalization of the TBA to the non-equilibrium case. In fact, in order to describe a non-equilibrium system we have to know all local and quasi-local charges which contribute to the density matrix. A convenient way to fix a GGE is to use the quasi-particle formulation.

### 4.1 Generalized Thermodynamic Bethe Ansatz

The thermodynamic Bethe ansatz can be extended [30] to the case with the Hamiltonian containing higher conserved charges. Consider the Hamiltonian given by

$$H(\{\beta\}) = \sum_n \beta_n Q_n \quad (4.1)$$

where  $Q_n$  are conserved charges in involution

$$[H_0, Q_i] = 0, \quad [Q_i, Q_j] = 0 \quad \forall \quad i, j. \quad (4.2)$$

The first three charges are well known, they are a number operator  $N = Q_0$ , the total momentum operator  $P = Q_1$  and the Hamiltonian  $H_0 = Q_2$ . The higher charges can be obtained from the algebraic Bethe ansatz formulation. The set of charges included in (4.1) can be extended in order to include quasi-local charges.

This formulation can be used to:



- extend the phase space of the Hamiltonian, considering the higher charges as interactions.
- calculate the averages of quantities using the density matrix of the Generalized Gibbs ensemble  $\rho_{GGE}$ .

We archive the generalized TBA modifying the energy (3.17) as follows

$$H(\rho^{(p)}) = L \sum_i^{\infty} \int d\theta \rho^{(p)}(\theta) \beta_i h_i(\theta) \quad (4.3)$$

where  $h_i(\theta)$  is the one-particle eigenvalue of the charges  $Q_i$ , and  $\beta_i$  are the associated potential. The minimization of free energy leads to

$$\epsilon(\theta) = w(\theta) - \int \frac{d\alpha}{2\pi} \varphi(\theta - \alpha) \log(1 + e^{-\epsilon(\alpha)}) \quad (4.4)$$

where the driving term is given by

$$w(\theta) = \sum_i \beta_i h_i(\theta). \quad (4.5)$$

The generalization of the generalized TBA to more complicated system (for example magnonic TBA's) is straightforward since only the driving term must be modified.

## 4.2 Conformal Field Theory out-of-equilibrium

In [38] and [3] were presented important results for conformal theories out-of-equilibrium. Consider a system obtained using the partition protocol. After putting together two independently thermalized systems at two different temperatures the propagation of energy, charge and other quantities take place. In the CFT quantities can be separated in two types: left-moving and right moving, which propagate at Fermi velocity  $v_F$ . The half of the energy is transported by the left-movers  $\frac{1}{2}h_l = \frac{c\pi}{12}T_L$  and the other half by the right-movers  $\frac{1}{2}h_r = \frac{c\pi}{12}T_R$ . Here  $c$  is the central charge of the model. Inside the light cone the mean energy current and the steady state energy current are given by

$$\begin{aligned} \langle j \rangle_{steadystate} &= \frac{c\pi}{12\hbar} k_B^2 (T_L^2 - T_R^2), \\ \langle h \rangle_{steadystate} &= \frac{c\pi}{12\hbar} k_B^2 (T_L^2 + T_R^2), \end{aligned} \quad (4.6)$$

we assume  $k_B = \hbar = 1$ .

### 4.3 GGE via quasi-particles

The main thing in the TBA is that the states are represented by quasi-particles, so a generic state can be imagined to be

$$|\theta_1, \theta_2, \dots\rangle. \quad (4.7)$$

The conserved charges act on this state as

$$Q_i |\theta_1, \theta_2, \dots\rangle = \sum_k h_i(\theta_k) |\theta_1, \theta_2, \dots\rangle \quad (4.8)$$

where  $h_i(\theta)$  is the one-particle eigenvalue of the conserved charge  $Q_i$ . In particular,

$$h_1(\theta) = E(\theta) = m \cosh(\theta), \quad h_2(\theta) = p(\theta) = m \sinh(\theta). \quad (4.9)$$

At this point we can forget about the conserved charges and consider only the one-particle eigenvalues. So, if we go to the thermodynamic limit the state (4.7) will contain a very large number of quasi-particles and therefore it will be convenient to pass to the description using densities as in (3.15).

The expectation values in the GGE read

$$\langle q_i \rangle_{GGE} = \frac{\text{Tr}[\rho_{GGE} q_i]}{\text{Tr}[\rho_{GGE}]} = \int d\theta \rho^{(p)}(\theta) h_i(\theta). \quad (4.10)$$

Since the set of functions  $h_i(\theta)$  is complete, both the set of  $\{q_i\}$  and the densities  $\{\rho^{(p)}\}$  completely characterize a GGE.

In the hydrodynamic approximation densities become space-time dependent

$$\rho^{(p)}(\theta) \rightarrow \rho^{(p)}(\theta, x, t), \quad \rho(\theta) \rightarrow \rho(\theta, x, t), \quad n(\theta) \rightarrow n(\theta, x, t) \quad (4.11)$$

and the expectation values become

$$\underline{q}_i(x, t) = \int d\theta \rho^{(p)}(\theta, x, t) h_i(\theta). \quad (4.12)$$

For the lightness of notation the space-time dependence will be suppressed.

The TBA formulation states that as a consequence of interaction we have the relation (3.20). It is possible to invert this relation for  $\rho^{(p)}$

$$2\pi \rho^{(p)}(\theta) = n(\theta) (p')^{dr}(\theta) \quad (4.13)$$

where we define the ‘‘dressing operator’’ as

$$h^{dr}(\theta) = h(\theta) + \int \frac{d\alpha}{2\pi} \varphi(\theta - \alpha) n(\alpha) h^{dr}(\alpha). \quad (4.14)$$

The occupation number is related to the pseudo-energy through the equation

$$n(\theta) = \frac{1}{1 + e^\epsilon(\theta)} \quad (4.15)$$

and the pseudo-energy can be calculated as in general TBA via the equation (4.4). Using the definition of the dressing operation, equation (4.12) can be recast in the form

$$\underline{q}_i = \int \frac{d\theta}{2\pi} (p')^{dr}(\theta) n(\theta) h_i(\theta) = \int \frac{d\theta}{2\pi} p'(\theta) n(\theta) h_i^{dr}(\theta). \quad (4.16)$$

Now we have the equation for the average densities. On the other side, the density of currents can be obtained considering the relativistic crossing symmetry. In fact, in the relativistic theory local currents in the crossing-channel are local densities. Consider the crossing operator  $\mathcal{C}$  which transforms the coordinates as

$$(x, t) \mapsto (it, -ix), \theta \mapsto i\pi/2 - \theta. \quad (4.17)$$

The action of this operator on local currents is

$$\mathcal{C}(j[h]) = iq[h^C] \quad (4.18)$$

where  $h^C = h(i\pi/2 - \theta)$  and  $q[h]$  and  $j[h]$  are densities and currents corresponding to one-particle eigenvalue  $h(\theta)$ . Consider also the relation:

$$\langle \mathcal{C}(\mathcal{O}) \rangle_w = \langle \mathcal{O} \rangle_{w^C}, \quad w^C(\theta) = w(i\pi/2 - \theta). \quad (4.19)$$

Where  $\langle \mathcal{O} \rangle_w$  is the average of some observables in the state characterized by the driving term  $w(\theta)$ . Note that the crossing operator has the property  $\mathcal{C}^2 = 1$ . So, applying  $\mathcal{C}$  on the current twice, we have

$$\langle \mathcal{C}(\mathcal{C}(j[h])) \rangle_w = \langle j[h] \rangle_w = i \langle q[h^C] \rangle_{w^C} \quad (4.20)$$

This yields to

$$\underline{j}_i = \int \frac{d\theta}{2\pi} E'(\theta) n(\theta) h_i^{dr}(\theta) = \int \frac{d\theta}{2\pi} (E')^{dr}(\theta) n(\theta) h_i(\theta). \quad (4.21)$$

One may also define the spectral current as

$$\rho^{(e)}(\theta) = n(\theta) (E')^{dr}(\theta) \quad (4.22)$$

and rewrite the previous equation as

$$\underline{j}_i = \int d\theta \rho^{(e)}(\theta) h_i(\theta). \quad (4.23)$$

At this point we can define the effective velocity in a simple way:

$$v^{eff}(\theta) = \frac{(E')^{dr}}{(p')^{dr}}. \quad (4.24)$$

This equation can be seen as the equation of state and, in this picture, quasi-particles are moving at effective velocities  $v^{eff}$ .

If we consider the relation

$$\rho^{(c)}(\theta) = v^{eff}(\theta)\rho^{(p)}(\theta) \quad (4.25)$$

and the definition of the dressing operation, the GGE equation of state may be written in the form

$$v^{eff}(\theta) = \frac{\rho_c(\theta)}{\rho_p(\theta)} = \frac{E'(\theta) + \int d\gamma \varphi(\theta - \gamma)\rho^{(c)}(\gamma)}{p'(\theta) + \int d\gamma \varphi(\theta - \gamma)\rho^{(p)}(\gamma)} \quad (4.26)$$

These relations completely characterize the GGE state through the kernel  $\varphi(\theta)$ . In terms of  $\rho^{(p)}(\theta)$  and  $v^{eff}(\theta)$ , GGE equation of state reads

$$v^{eff}(\theta) = v^{gr}(\theta) + \int d\alpha \varphi(\theta - \alpha)\rho^{(p)}(\alpha) \frac{(v^{eff}(\alpha) - v^{eff}(\theta))}{p'(\theta)} \quad (4.27)$$

where  $v^{gr}(\theta) = E'(\theta)/p'(\theta)$  is the group velocity. In this representation the equation of state is seen as the equation for effective velocity which is obtained as modification of group velocity. In this form it is clear that  $\rho^{(p)}(\theta)$  completely determinate the state.

## 4.4 Euler equation

Consider the Euler equation (1.14). Using the fact that the set of functions  $h(\theta)$  is complete, it is possible to recast the Euler equation in the form

$$\partial_t \rho^{(p)}(\theta) + \partial_x \rho^{(c)}(\theta) = 0 \quad (4.28)$$

or

$$\partial_t \rho^{(p)}(\theta) + \partial_x (v^{eff}(\theta)\rho^{(p)}(\theta)) = 0 \quad (4.29)$$

A more convenient way to represent this equation is through the occupation number  $n(\theta)$ . Note that the dressing operation can be expressed in operator language as

$$h^{dr} = (1 - \varphi \mathcal{N})^{-1} h \quad (4.30)$$

where  $\mathcal{N}$  is diagonal operator associated to the occupation number. From (4.16) and (4.21) it is easy to see that the operator

$$\mathcal{U} = \mathcal{N}(1 - \varphi \mathcal{N})^{-1} h \quad (4.31)$$

is symmetric under the bilinear form

$$x \cdot y = \int \frac{d\theta}{2\pi} x(\theta)y(\theta). \quad (4.32)$$

In fact, we have

$$\underline{q}_i = h_i \cdot \mathcal{U}p' = p' \cdot \mathcal{U}h_i, \quad \underline{j}_i = h_i \cdot \mathcal{U}E' = E' \cdot \mathcal{U}h_i. \quad (4.33)$$

Then, write (4.28) in the form

$$\partial_t(n(\theta)(p')^{dr}(\theta) + \partial_x(n(\theta)(E')^{dr}(\theta)) = \partial_t(\mathcal{U}p'(\theta)) + \partial_x(\mathcal{U}E'(\theta)) = 0 \quad (4.34)$$

where we have used the relation  $\rho^{(c)}(\theta) = \frac{n(\theta)}{2\pi}(E')^{dr}\theta$ . From the conservation equation it follows that

$$\partial_t p'(\theta) + \partial_x E'(\theta) = 0. \quad (4.35)$$

So, we have to evaluate the partial derivative of symmetric operator  $\mathcal{U}$  with respect to  $a = \{x, t\}$ . Note that

$$(1 - \varphi\mathcal{N})^{-1} = 1 + \varphi\mathcal{N} + \varphi\mathcal{N}\varphi\mathcal{N} + \dots \quad (4.36)$$

and

$$\begin{aligned} \partial_a \mathcal{U} &= \partial_a \mathcal{N} + \partial_a \mathcal{N} \varphi \mathcal{N} + \mathcal{N} \varphi \partial_a \mathcal{N} + \partial_a \mathcal{N} \varphi \mathcal{N} \varphi \mathcal{N} + \dots \\ &= (1 - \varphi\mathcal{N})^{-1} (\partial_a \mathcal{N}) (1 - \varphi\mathcal{N})^{-1}. \end{aligned} \quad (4.37)$$

The equation (4.34) becomes:

$$(1 - \varphi\mathcal{N})^{-1} (\partial_t \mathcal{N}) (1 - \varphi\mathcal{N})^{-1} p'(\theta) + (1 - \varphi\mathcal{N})^{-1} (\partial_x \mathcal{N}) (1 - \varphi\mathcal{N})^{-1} E'(\theta) = 0. \quad (4.38)$$

Dividing by  $(1 - \varphi\mathcal{N})^{-1}$  and rewriting in terms of dressing operator leads to

$$(\partial_t n(\theta))(p')^{dr}(\theta) + (\partial_x n(\theta))(E')^{dr}(\theta) = 0 \quad (4.39)$$

and using the relation for the effective velocity, yields

$$\partial_t n(\theta) + v^{eff}(\theta) \partial_x n(\theta) = 0. \quad (4.40)$$

The hydrodynamic equation in the coordinates of occupation number has diagonal Jacobian and in this case the effective velocities correspond to the propagation velocities of the normal modes  $n(\theta)$ .

Loking at (4.40) and (4.29) it is easy to see that the continuity equation (4.29) holds also for the density of states and density of holes, defined as

$$\rho(\theta) = \frac{\rho^{(p)}(\theta)}{n(\theta)}, \quad \rho_h(\theta) := \rho(\theta) - \rho^{(p)}(\theta). \quad (4.41)$$

It is easy to show that the entropy density

$$s(\theta) = \rho(\theta) \log \rho(\theta) - \rho^{(p)}(\theta) \log \rho^{(p)}(\theta) - \rho_h(\theta) \log \rho_h(\theta) \quad (4.42)$$

is conserved

$$\partial_t s(\theta) + \partial_x (v^{eff}(\theta) s(\theta)) = 0. \quad (4.43)$$

The integral  $\int d\theta s(\theta)$  represents the specific entropy per cell at the position  $(x, t)$ . This is the von Neumann entropy of the GGE. The production of entropy is related to the viscosity of the fluid. In fact, in this case the conservation of entropy implies the null viscosity term.

## 4.5 Riemann problem

Solving the two-reservoir system corresponds to solving the initial value problem:

$$\begin{cases} \partial_t n(x, t, \theta) + v^{eff}(\theta) \partial_x n(x, t, \theta) = 0 \\ n(x, 0, \theta) = n_i(x, \theta). \end{cases} \quad (4.44)$$

The initial condition is given by

$$n_i(x, \theta) = n_L(\theta) \Theta(-x) + n_R(\theta) \Theta(x) \quad (4.45)$$

where  $\Theta(x)$  is the step function and  $n_L \setminus n_R$  is the occupation number that characterizes the system in thermal equilibrium at temperatures  $T_L \setminus T_R$ . One can write the ansatz

$$n(x, t, \theta) = n_i(x - v^{eff}(\theta)t, \theta) \quad (4.46)$$

or in the form of (4.5), the occupation number function reads

$$n(x, t, \theta) = n_L(\theta) \Theta(-x + v^{eff}(\theta)t) + n_R(\theta) \Theta(x - v^{eff}(\theta)t). \quad (4.47)$$

In the case where  $v^{eff}$  is monotonic in  $\theta$ , the equation

$$v^{eff}(\theta)t - x = 0, \quad (4.48)$$

for fixed  $t$  and  $x$ , has a unique solution  $\theta^*$

$$v^{eff}(\theta^*(x, t)) = \frac{x}{t}. \quad (4.49)$$

So, the solution to the initial value problem can be written as

$$\begin{cases} n(x, t, \theta) = n_L(\theta) \Theta(\theta - \theta^*(x, t)) + n_R(\theta) \Theta(\theta_\star(x, t) - \theta) \\ v^{eff}(\theta_\star(x, t)) = \frac{x}{t}. \end{cases} \quad (4.50)$$

At long time we may use scale-invariance property of the system which states that the occupation number depends on the ray variable

$$\xi = \frac{x}{t}, \quad n(x, t, \theta) = n(\xi, \theta) \quad (4.51)$$

The first equation of the system (4.44) can be recast in the form

$$(v^{eff}(\theta) - \xi)\partial_\xi n(\theta) = 0. \quad (4.52)$$

The solution of this equation is given by

$$\begin{cases} n(\theta) = n_L(\theta)\Theta(\theta - \theta_*(\xi)) + n_R(\theta)\Theta(\theta_*(\xi) - \theta) \\ v^{eff}(\theta_*) = \xi. \end{cases} \quad (4.53)$$

The position of the  $\theta_*$  is determined by the ray variable  $\xi$  and it is self-consistently determined by the second equation of the previous system. The solution in this form has much of physical sense, in fact, it says that particles very far away on the right or on the left are still described by the occupation numbers  $n_L(\theta)$  and  $n_R(\theta)$ .

---

## GHD for perturbed minimal models

---

In this chapter we will study the extension of GHD to the case of minimal models perturbed by the relevant operator  $\Phi_{13}$ . The non-diagonal scattering yields to a more complicated set of TBA equations where the pseudo-energies associated to the quasi-particles are coupled to the magnonic pseudo-energies. This non trivial coupling produces a complication in the computation of normal modes and propagation velocities of the GHD.

Our analysis will start with the perturbed Tricritical Ising Model (TIM). This model is the simplest model of the unitary series of models with non-diagonal S-matrix and its spectrum is composed by one pseudo-particle and one magnon. This study is particularly instructive because it underlies the principal features of the model with non diagonal scattering.

### 5.1 Tricritical Ising Model: general features

The tricritical Ising model [39, 40] is the unitary model  $\mathcal{M}_4$  with the central charge  $c = 7/10$ . Couplings constants have the following meaning:

- $\lambda_1$  external magnetic field,
- $\lambda_2$  displacement of the temperature from its critical value  $(T - T_c)$ ,
- $\lambda_3$  subleading magnetic field,
- $\lambda_4$  chemical potential for the vacancies.



$\frac{3}{2}$	$\frac{7}{16}$	0
$\frac{6}{10}$	$\frac{3}{80}$	$\frac{1}{10}$
$\frac{1}{10}$	$\frac{3}{80}$	$\frac{6}{10}$
0	$\frac{7}{16}$	$\frac{3}{2}$

Table 5.1: Kac table of tricritical Ising model.

Identity	$\Phi_{11}$	$\mathcal{I}$	0
Magnetization field	$\Phi_{22}$	$\sigma$	$\frac{3}{80}$
Sub-leading magnetization	$\Phi_{12}$	$\sigma'$	$\frac{7}{16}$
Energy density	$\Phi_{21}$	$\epsilon$	$\frac{1}{10}$
Vacancy or sub-leading energy	$\Phi_{13}$	$\epsilon'$	$\frac{6}{10}$
Irrelevant field	$\Phi_{41}$	$\epsilon''$	$\frac{3}{2}$

Table 5.2: List of all fields of TIM at tricritical point.

It describes the scaling region near the tricritical point and it represents the universality class of the Landau-Ginzburg theory

$$\int \Phi \exp\left\{-\int [(\nabla\Phi)^2 + \lambda_6\Phi_{41}^6 + \lambda_4\Phi_{13}^4 + \lambda_3\Phi_{21}^3 + \lambda_2\Phi_{12}^2 + \lambda_1\Phi_{11}]d^2r\right\} \quad (5.1)$$

where the tricritical point is reached if  $\lambda_1 = \lambda_2 = \lambda_3 = \lambda_4 = 0$ . At the critical point, the operator content is given in the Table 5.1 and the operators are described in the table 5.2.

The corresponding lattice model is defined like an ordinary Ising model, except for the presence of vacant sites. The configuration energy of the model reads

$$E[\sigma_i, t_i] = -\sum_{(ij)} t_i t_j (K + \delta_{\sigma_i, \sigma_j}) - \mu \sum_i t_i \quad (5.2)$$

where  $\mu$  is the chemical potential,  $t_i = \sigma_i^2$  specify if the site  $i$  is vacant ( $t_i = 0$ ) or not ( $t_i = 1$ ) and  $K$  is the energy of unlike spins, and  $K + 1$  energy of like spins.

We are interested in the field theory arisen as the perturbation of the unitary CFT minimal model perturbed by the relevant scalar operator  $\epsilon' = \Phi_{13}$ :

$$\mathcal{A} = \mathcal{A}_{CFT} + \lambda_4 \int \Phi_{13}(x) d^2x \quad (5.3)$$

where  $\lambda_4 < 0$ .

## 5.2 GHD and TBA for TIM

The relations between magnonic and particle densities, for  $\Phi_{13}$ -perturbed TIM, can be obtained from equations (3.122) and (3.123). By setting  $m = 2$ ,  $l = 1$  and  $k = 2$  we obtain equations for TIM

$$\begin{aligned}\rho(\theta) &= \frac{m}{2\pi} \cosh(\theta) + (\varphi * \mu_1^{(p)})(\theta), \\ \mu_1(\theta) &= (\varphi * \rho^{(p)})(\theta)\end{aligned}\tag{5.4}$$

where the kernel is

$$\varphi(x) = \frac{1}{\cosh(x)}.\tag{5.5}$$

The transformations from occupation numbers to particles densities are given by

$$\begin{aligned}2\pi\rho^{(p)}(\theta) &= n(\theta)(p')^{dr}(\theta), \\ 2\pi\mu^{(p)}(\theta) &= n_1(\theta)(p_1')^{dr}(\theta)\end{aligned}\tag{5.6}$$

where the “dressing” operators are defined as follow:

$$\begin{aligned}h^{dr}(\theta) &= h(\theta) + \int \frac{d\beta}{2\pi} \varphi(\theta - \beta) n_1(\beta) (h_1)^{dr}(\beta), \\ h_1^{dr}(\theta) &= \int \frac{d\beta}{2\pi} \varphi(\theta - \beta) n(\beta) (h)^{dr}(\beta)\end{aligned}\tag{5.7}$$

where  $h^{dr}(\theta)$  can be interpreted as quasi-particle dressing operator and  $h_1^{dr}(\theta)$  as magnon dressing operator. The occupation numbers are related to pseudo-energy and particle/magnon densities by

$$n(\theta) = \frac{1}{1 + \exp(\epsilon(\theta))} = \frac{\rho^{(p)}(\theta)}{\rho(\theta)}, \quad n_1(\theta) = \frac{1}{1 + \exp(\epsilon_1(\theta))} = \frac{\mu^{(p)}(\theta)}{\mu(\theta)}.\tag{5.8}$$

Using the same parameters in the equations (3.127), we obtain a set of equilibrium TBA equations for perturbed TIM, which are given by

$$\begin{aligned}\epsilon(\theta) &= \frac{m}{T} \cosh(\theta) - \frac{1}{2\pi} (\varphi * L(\epsilon_1))(\theta), \\ \epsilon_1(\theta) &= -\frac{1}{2\pi} (\varphi * L(\epsilon))(\theta)\end{aligned}\tag{5.9}$$

where

$$L(f(x)) = \log(1 + e^{-f(x)}).\tag{5.10}$$

The spectrum of perturbed TIM is composed by one stable quasi-particle of mass  $m$  and one massless magnon. The TBA can be represented by Dynkin diagram as in (fig.5.1).

The next step is to find a set of generalized TBA equations which describes a non-equilibrium situation. To this purpose we must modify the free energy which minimization leads to the TBA equations. In fact, the equation (3.125) must be substituted

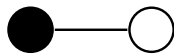

Figure 5.1:  $A_2$  Dynking diagram: black node refers to the massive particle and white node represents the magnon.

by a quantity which takes in account all local and quasi-local conserved charges. These charges must fully characterize the GGE. The construction of the GGE for non-diagonal scattering theories is described in [41]. The main difference from the case of diagonal S-matrix resides in the fact that the charges contained in the GGE act non trivially on the magnonic configurations. It means that, in the thermodynamic limit, densities of the conserved quantities are given by

$$\langle q_i \rangle_{GGE} \sim \int d\theta \rho^{(p)}(\theta) h_i(\theta) + \int d\theta \mu^{(p)}(\theta) g_i(\theta) \quad (5.11)$$

where  $h_i$  are one particle eigenvalues of conserved charges in quasi-particle configuration and  $g_i$  are one particle eigenvalues in magnonic configurations. So, we modify the equation (3.125) as follows

$$E(\theta) \rightarrow E(\theta) = \int d\theta \rho^{(p)}(\theta) \beta_i h_i(\theta) + \int d\theta \mu^{(p)}(\theta) \eta_i g_i(\theta). \quad (5.12)$$

As a result of free energy minimization, we obtain the following generalized TBA equations

$$\begin{aligned} \epsilon(\theta) &= w(\theta) - \frac{1}{2\pi} (\varphi * L(\epsilon_1))(\theta), \\ \epsilon_1(\theta) &= u(\theta) - \frac{1}{2\pi} (\varphi * L(\epsilon))(\theta) \end{aligned} \quad (5.13)$$

where

$$w(\theta) = \sum_i \beta_i h_i(\theta), \quad u(\theta) = \sum_i \eta_i g_i(\theta). \quad (5.14)$$

$\beta_i$  and  $\eta_i$  are generalized temperatures. Note that contrary to the standard TBA equations (5.9), the generalized TBA equation present a driving term  $u(\theta)$  in the magnonic equation. This statement is also supported by the numerical analysis, as evident from the fig.5.2. The first two charges in  $w(\theta)$  are, as commonly in relativistic models, energy and momentum

$$h_1(\theta) = E(\theta) = m \cosh(\theta), \quad h_2(\theta) = p(\theta) = m \sinh(\theta). \quad (5.15)$$

Now we turn to the generalized hydrodynamic formulation of the system. The quantities become space-time dependent:

$$\begin{aligned} \rho^{(p)}(\theta) &\rightarrow \rho^{(p)}(\theta, x, t), & \rho(\theta) &\rightarrow \rho(\theta, x, t), & n(\theta) &\rightarrow n(\theta, x, t), \\ \mu^{(p)}(\theta) &\rightarrow \mu^{(p)}(\theta, x, t), & \mu(\theta) &\rightarrow \mu(\theta, x, t), & n_1(\theta) &\rightarrow n(\theta, x, t), \\ h^{dr}(\theta) &\rightarrow h^{dr}(\theta, x, t), & h_1^{dr}(\theta) &\rightarrow h_1^{dr}(\theta, x, t). \end{aligned} \quad (5.16)$$

We omit the space-time dependence to keep the equations more readable.

In order to obtain the Euler equations of TIM we write two differential equations, one for the particle densities and one for the magnonic densities:

$$\begin{aligned}\partial_t[\rho^{(p)}(\theta)] + \partial_x[v^{eff}(\theta)\rho^{(p)}(\theta)] &= 0, \\ \partial_t[\mu^{(p)}(\theta)] + \partial_x[v_1^{eff}(\theta)\mu^{(p)}(\theta)] &= 0.\end{aligned}\tag{5.17}$$

where the effective velocities are defined as

$$v^{eff}(\theta) = \frac{(E')^{dr}(\theta)}{(p')^{dr}(\theta)}, \quad v_1^{eff}(\theta) = \frac{(E'_1)^{dr}(\theta)}{(p'_1)^{dr}(\theta)}.\tag{5.18}$$

Now, if we put equations (5.6) into (5.17), we obtain

$$\begin{aligned}\partial_t[n(\theta)(p')^{dr}(\theta)] + \partial_x[n(\theta)(E')^{dr}(\theta)] &= 0, \\ \partial_t[n_1(\theta)(p'_1)^{dr}(\theta)] + \partial_x[n_1(\theta)(E'_1)^{dr}(\theta)] &= 0.\end{aligned}\tag{5.19}$$

These can be written as two Euler equations (see the computation in Appendix B) with propagation velocities  $v^{eff}(\theta)$  and  $v_1^{eff}(\theta)$  and normal modes  $n(\theta)$  and  $n_1(\theta)$

$$\begin{aligned}[\partial_t + v^{eff}\partial_x]n(\theta) &= 0, \\ [\partial_t + v_1^{eff}\partial_x]n_1(\theta) &= 0.\end{aligned}\tag{5.20}$$

So, we obtain the occupation numbers  $n(\theta)$  and  $n_1(\theta)$  by solving Euler equations (5.20). These completely characterize all conserved quantities contained in the GGE. For example, consider the densities of conserved charges characterized only by the particle densities

$$\underline{q}_i(x, t) = \int d\theta \rho^{(p)}(\theta) h_i(\theta) = \int \frac{d\theta}{2\pi} (p')^{dr}(\theta) n(\theta) h_i(\theta)\tag{5.21}$$

and (as demonstrated in Appendix B) also for TIM holds the equation

$$\underline{q}_i(x, t) = \int \frac{d\theta}{2\pi} (p')(\theta) n(\theta) h_i^{dr}(\theta).\tag{5.22}$$

Similarly, as was described in the case of diagonal S-matrix, we can compute the GGE averages of currents by using relativistic crossing symmetry argument. The expression for the current is

$$\underline{j}_i(x, t) = \int \frac{d\theta}{2\pi} (E')^{dr}(\theta) n(\theta) h_i(\theta) = \int \frac{d\theta}{2\pi} (E')(\theta) n(\theta) h_i^{dr}(\theta).\tag{5.23}$$

In the same way we can calculate the GGE averages of conserved charges characterized by the magnonic densities.

### 5.3 Partitioning protocol and numerical analysis

Consider a system constructed as in partitioning protocol. We must solve a system of equations given by (5.20) with initial conditions

$$\begin{aligned} n(\theta, x, 0) &= n^L(\theta)\Theta(-x) + n^R\Theta(x), \\ n_1(\theta, x, 0) &= n_1^L(\theta)\Theta(-x) + n_1^R\Theta(x) \end{aligned} \quad (5.24)$$

Now consider the large scale limit  $(x, t) \rightarrow (ax, at), a \rightarrow \infty$ . We assume the self-similar solution  $n(\theta, x, t) \rightarrow n(\theta, \xi)$  depending on the ray variable  $\xi = x/t$ . So, we have to solve the following set of differential equations

$$\begin{aligned} (v^{eff}(\xi) - \xi)\partial_\xi n(\xi) &= 0, \\ \lim_{\xi \rightarrow \pm\infty} n(\theta, \xi) &= n(\theta)^{R/L}, \\ (v_1^{eff}(\xi) - \xi)\partial_\xi n_1(\xi) &= 0, \\ \lim_{\xi \rightarrow \pm\infty} n_1(\theta, \xi) &= n_1(\theta)^{R/L}. \end{aligned} \quad (5.25)$$

The solution to this set of equations is given by

$$\begin{aligned} n(\theta) &= n^L(\theta)\Theta(\theta - \theta^*) + n^R(\theta)\Theta(\theta^* - \theta) \\ v^{eff}(\theta^*, \xi) &= \xi \\ n_1(\theta) &= n_1^L(\theta)\Theta(\theta - \theta_1^*) + n_1^R(\theta)\Theta(\theta_1^* - \theta) \\ \bar{v}^{eff}(\theta_1^*, \xi_1) &= \xi_1. \end{aligned} \quad (5.26)$$

We evaluate this solution numerically. First we find two positions of discontinuity  $\xi$  and  $\xi_1$  and then we construct two occupation numbers  $n(\theta)$  and  $n_1(\theta)$ .

The numerical results was obtained by solving the integral equations. The numerical procedure to calculate  $n(\theta)$  can be summarized as follows:

1. Solve the TBA equation for the right and left system, using the driving term  $w(\theta) = \beta_{L/R} \cosh \theta$ . The TBA equations can be solved numerically by using the

following converging iterative procedure

$$\begin{aligned}
\epsilon[1](\theta_i) &= w(\theta_i), \\
\epsilon_1[1](\theta_i) &= -\frac{1}{2\pi}(\varphi * L(\epsilon[1]))(\theta_i), \\
\epsilon[2](\theta_i) &= w(\theta_i) - \frac{1}{2\pi}(\varphi * L(\epsilon_1[1]))(\theta_i), \\
\epsilon_1[2](\theta_i) &= -\frac{1}{2\pi}(\varphi * L(\epsilon[2]))(\theta_i), \\
&\dots \\
\epsilon[n](\theta_i) &= w(\theta_i) - \frac{1}{2\pi}(\varphi * L(\epsilon_1[n-1]))(\theta_i), \\
\epsilon_1[n](\theta_i) &= -\frac{1}{2\pi}(\varphi * L(\epsilon[n]))(\theta_i).
\end{aligned} \tag{5.27}$$

We have discretized the rapidity space  $\theta_i \in \mathcal{A}$ . The interval  $\mathcal{A}$  must be chosen very carefully by studying the convergence of the  $L$ -function. The pseudoenergies converge very rapidly (after  $\sim 15$  iterations).

2. Compute the occupation numbers  $n(\theta)$  and  $n_1(\theta)$  as in relations (5.8).
3. Set some value of the ray  $\xi$ . The maximum propagation velocity of excitations, in the relativistic case, is set to  $|1|$ . Beyond this value we obtain a asymptotic bath. So, we will study the behavior of the system in the interval  $\xi \in [1, -1]$ .
4. In order to find the position of the discontinuity one have to solve the second and the fourth equations of (5.37). For this purpose, we start with choosing  $\theta^*$  and  $\theta_1^*$  to be some trivial value (for example  $\theta^* = \theta_1^* = 0$ ).
5. Compute  $v^{eff}(\theta^*, \xi)$  and  $v^{eff}(\theta_1^*, \xi_1)$ , the solution of the second and of the fourth equations of (5.37) will give a new value for  $\theta^*$  and for  $\theta_1^*$ .
6. Repeat the previous two steps for a few times. This is a convergent procedure, generally, the solution become stable after  $\sim 10$  iterations.
7. Employ the stable  $\theta^*$  and  $\theta_1^*$  to compute the total occupation number as in the first and in the third equations of (5.37).
8. With the total occupation number we can compute all dressed quantities that we want through the equation (5.7).
9. Finally, we can use the occupation number and the dressing quantity to calculate the averages of local densities (5.22) and of their associated currents (5.23).
10. This procedure can be repeated for different values of  $\xi$ .

In Fig.5.2 we show the driving term  $u(\theta)$  of the magnonic TBA equation describing the steady-state along the ray  $\xi = 0$ . Note that as the difference between bath's temperatures go to zero the deviation from zero becomes smaller. At equilibrium, when  $T_L = T_R$ , the driving term vanishes.

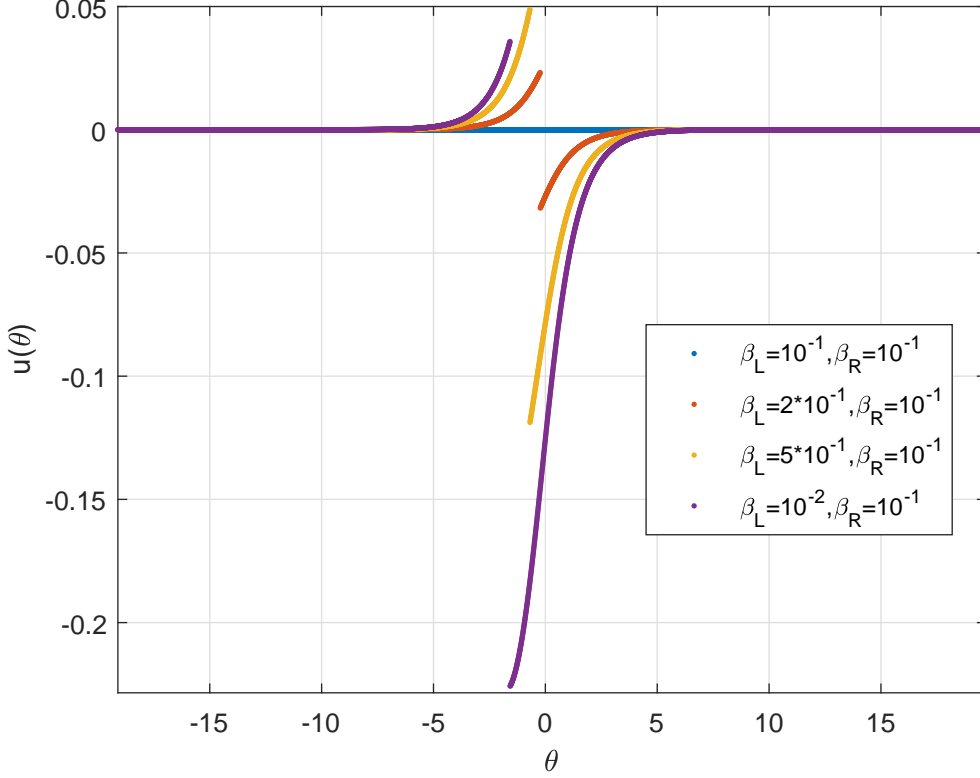

Figure 5.2: Plot of the magnonic driving term in the case of systems with four different asymptotic reservoirs configurations and  $\xi = 0$ .

In Fig.5.3 we depict the driving term  $w(\theta)$  for different configurations of head baths. In the equilibrium situations the driving term is given by  $w(\theta) = \frac{m}{T} \cosh(\theta)$ . With a choice of the baths with different temperatures the driving term differ from the equilibrium one.

In the Table 5.3 we report the central charge of the non-equilibrium TIM for different configurations. The central charge was calculated by using the first equation of (4.6).

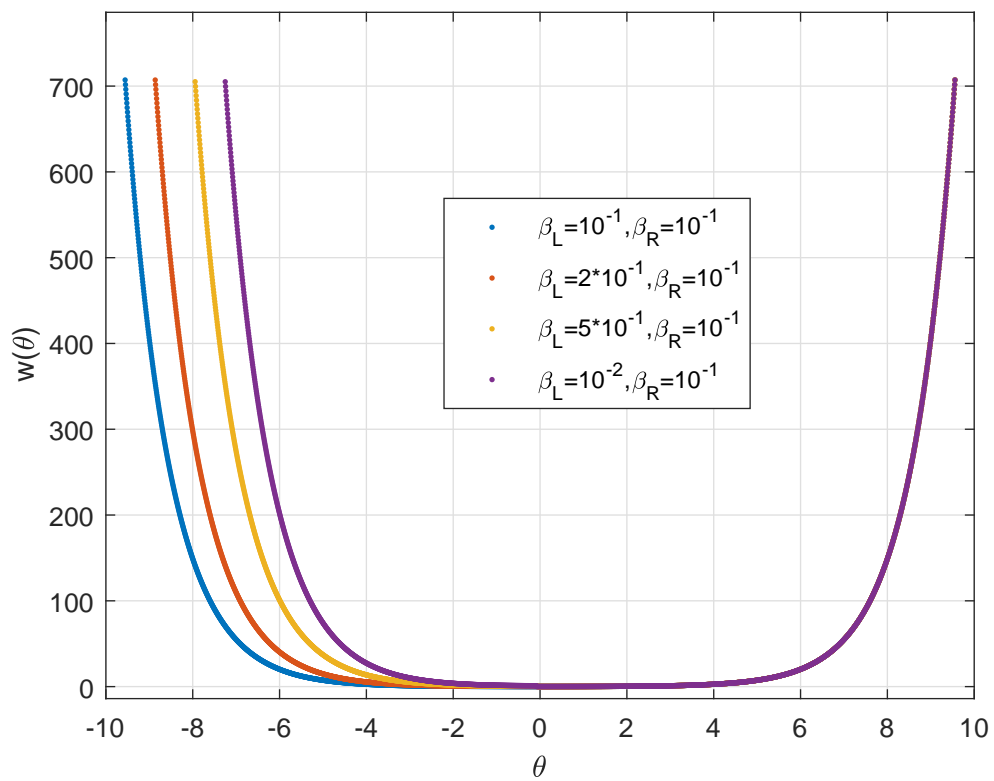

Figure 5.3: Plot of the particle driving term in the case of systems with four different asymptotic reservoirs configurations and  $\xi = 0$ .



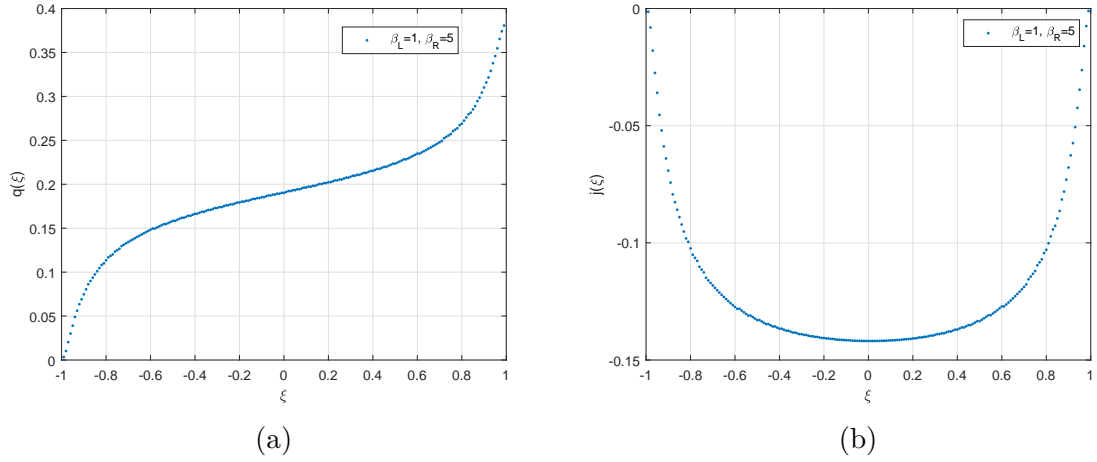

Figure 5.4: Charge density in (a) and current densities in (b) as functions of ray  $\xi$ . Note that near asymptotic baths ( $\xi \rightarrow \pm 1$ ) current density tends to zero.

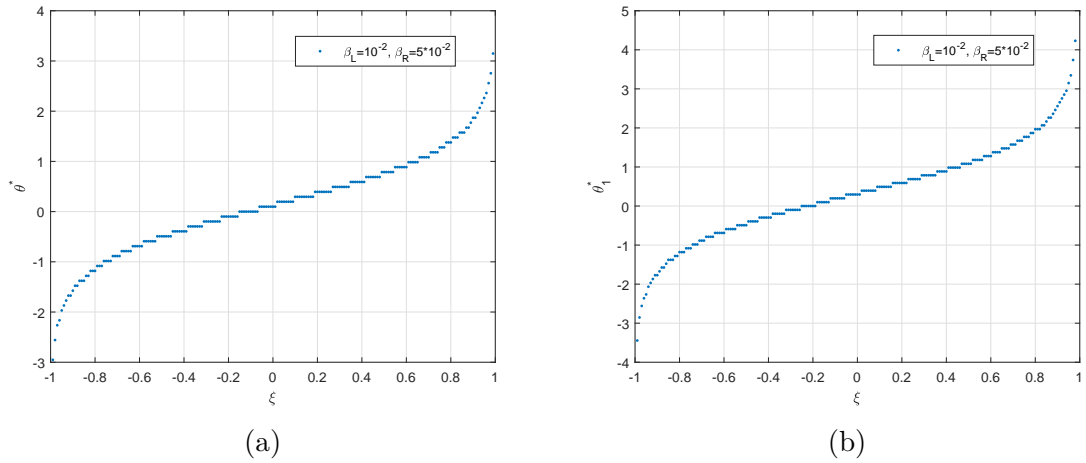

Figure 5.5: Distribution of the positions  $\theta^*$  in (a) and  $\theta_1^*$  in (b) as functions of the ray  $\xi$ .

## 5.4 Generalization to minimal models

The generalization to higher perturbed minimal models is straightforward. Consider the equations for particles densities (3.122) and strings (magnons) densities (3.123). We obtain the minimal models by setting  $m = 2$ ,  $k > 2$  ( $k = 2$  corresponds to TIM) and

$\beta_L$	$\beta_R$	$\xi$	c
1	10	0	0.555258630559526
0.1	1	0	0.698301705693532
0.01	0.1	0	0.699968592723645
0.001	0.01	0	0.699999234257869
0.00001	0.0001	0	0.699999998631212

Table 5.3: Numerical computation of the central charge of non-equilibrium TIM. In the scaling regime the central charge of TIM is equal to 0.7.

$l = 1$ . The resulting equations are

$$\begin{aligned}
2\pi\rho(\theta) &= \cosh(\theta) + (\varphi * \mu^{(p)})(\theta), \\
2\pi\mu_n(\theta) &= \delta_{n,k-1}(\varphi * \rho^{(p)})(\theta) + \sum_{\substack{q=1 \\ q \neq n}}^{k+1} (\varphi * \mathcal{I}_{nq}^{k+1} \mu_q^{(p)})(\theta)
\end{aligned} \tag{5.28}$$

where  $n = 1, 2, \dots, k-1$ . These equations can be recast in the following form

$$\begin{aligned}
2\pi\rho^{(p)}(\theta) &= n(\theta)(p)^{dr}(\theta), \\
2\pi\rho_n^{(p)}(\theta) &= n_n(\theta)(p_n)^{dr}(\theta),
\end{aligned} \tag{5.29}$$

where the dressing functions are defined as

$$\begin{aligned}
(h)^{dr}(\theta) &= h(\theta) + \frac{1}{2\pi}(\varphi * n_{k-1}(h)_{k-1}^{dr})(\theta), \\
(h)_n^{dr}(\theta) &= \delta_{n,k-1} \frac{1}{2\pi}(\varphi * n(h)^{dr})(\theta) + \frac{1}{2\pi} \sum_{\substack{q=1 \\ q \neq n}}^{k+1} (\varphi * \mathcal{I}_{nq}^{k+1} n_q(h_q)^{dr})(\theta).
\end{aligned} \tag{5.30}$$

The standard TBA equations of the minimal models are

$$\begin{aligned}
\epsilon(\theta) &= \frac{m}{T} \cosh(\theta) - \frac{1}{2\pi}(\varphi * L^{(r)}(\epsilon_{k-1}))(\theta), \\
\epsilon_n^{(r)}(\theta) &= -\delta_{n,k-1} \frac{1}{2\pi}(\varphi * L(\epsilon))(\theta) - \frac{1}{2\pi} \sum_{\substack{q=1 \\ q \neq n}}^{k+1} (\varphi * \mathcal{I}_{nq}^{k+1} L^{(r)}(\epsilon_q))(\theta).
\end{aligned} \tag{5.31}$$

In the non-equilibrium situation a system is described by the generalized TBA which characterize the generalized Gibbs ensemble. The new TBA equations are

$$\begin{aligned}
\epsilon(\theta) &= w(\theta) - \frac{1}{2\pi}(\varphi * L^{(r)}(\epsilon_{k-1}))(\theta), \\
\epsilon_n^{(r)}(\theta) &= u_n(\theta) - \delta_{n,k-1} \frac{1}{2\pi}(\varphi * L(\epsilon))(\theta) - \frac{1}{2\pi} \sum_{\substack{q=1 \\ q \neq n}}^{k+1} (\varphi * \mathcal{I}_{nq}^{k+1} L^{(r)}(\epsilon_q))(\theta).
\end{aligned} \tag{5.32}$$

where the driving terms are given by

$$w(\theta) = \sum_i \beta_i h_i(\theta), \quad u_n(\theta) = \sum_i \eta_{n,i} g_{n,i}(\theta). \quad (5.33)$$

We assume the generalized hydrodynamic approximation where quantities become space-time dependent. The Euler equation holds for occupation number of particles and magnons

$$\begin{aligned} [\partial_t + v^{eff}(\theta) \partial_x] n(\theta) &= 0, \\ [\partial_t + v_n^{eff}(\theta) \partial_x] n_n(\theta) &= 0, \end{aligned} \quad (5.34)$$

where

$$v^{eff}(\theta) = \frac{(E')^{dr}(\theta)}{(p')^{dr}(\theta)}, \quad v_n^{eff}(\theta) = \frac{(E'_n)^{dr}(\theta)}{(p'_n)^{dr}(\theta)}. \quad (5.35)$$

For the partition protocol we have the following set of equations

$$\begin{aligned} (v^{eff}(\xi) - \xi) \partial_\xi n(\xi) &= 0, \\ \lim_{\xi \rightarrow \pm\infty} n(\theta, \xi) &= n(\theta)^{R/L}, \\ (v_n^{eff}(\xi) - \xi) \partial_\xi n_n(\xi) &= 0, \\ \lim_{\xi \rightarrow \pm\infty} n_n(\theta, \xi) &= n_n(\theta)^{R/L}. \end{aligned} \quad (5.36)$$

We have a solution for the particle and  $n$  solutions for the magnons

$$\begin{aligned} n(\theta) &= n^L(\theta) \Theta(\theta - \theta^*) + n^R(\theta) \Theta(\theta^* - \theta) \\ v^{eff}(\theta^*, \xi) &= \xi \\ n_1(\theta) &= n_n^L(\theta) \Theta(\theta - \theta_n^*) + n_n^R(\theta) \Theta(\theta_n^* - \theta) \\ \bar{v}^{eff}(\theta_n^*, \xi_n) &= \xi_n. \end{aligned} \quad (5.37)$$

## CHAPTER 6

---

### Conclusions and perspectives

---

The aim of this thesis was to study the generalized hydrodynamic formulation in the context of the integrable  $(1 + 1)$ -D quantum field theories. The integrable structure of these field theories is strictly related to the form of associated S-matrix which is the fundamental constituent of the thermodynamic Bethe ansatz. In the case of diagonal scattering matrix, the GHD was formulated a few years ago.

In this thesis we proposed a generalization of the GHD approach to a class of  $(1 + 1)$ -D integrable field theories described by non diagonal S-matrix. These kind of theories present several complications. The derivation of TBA equations is more tricky because in the thermodynamic limit internal degrees of freedom (magnons) appear. In TBA equations magnons arise as particles without mass with corresponding TBA equations having vanishing driving term.

The non-equilibrium situations are described by generalized TBA equations. To compute these equations we include in the free energy conserved charges that characterize GGE. The generalized TBA equations contain a driving term with a set of conserved charges which determinate the non-equilibrium behavior of the system. In our analysis it comes out that the magnonic driving term becomes non-vanishing in some non-equilibrium systems.

We formulated the GHD for  $\Phi_{13}$ -perturbed minimal models. In particular, we solved the problem for partition protocol. We have studied numerically the perturbed tricritical Ising model. These analysis confirm our prediction about magnonic driving term which results to have a non vanishing nature in the non-equilibrium case. We have also analyzed the conformal limit of the theory. In this regime the central charge of the model is correctly computed from the equation proposed in [38].

There are a few others directions to explore:

- the generalized hydrodynamic description, presented in this work, holds only on certain time and space scales. Namely when  $x \sim t$  and  $t$  is assumed greater than any other observable. At smaller scales different physical phenomena can take place, for example dissipation and diffusion [42].
- a deeper understanding of non-equilibrium systems can be reached from the computation of the local and quasi-local charges which are the building blocks of the generalized Gibbs ensemble. The generalized hydrodynamic approach allows to compute quantities in the GGE but not to extract information about which charges enter the GGE.
- in order to underline the symmetries and the algebraic structure of the system, it is possible to study a reformulation of the non-equilibrium framework in terms of Y-systems and T-systems.
- a further complication arises when there are infinite number of TBA equations. For this system there exists a non-linear integral equation (NLIE), which instead of containing infinitely many equations is represented by a unique equation. The deduction of NLIE for the non-equilibrium situation would be a crucial step forward.

## APPENDIX A

---

### Thermalization in closed many body quantum systems

---

Consider a system prepared in some arbitrary initial state  $|\psi_0\rangle$  and let this system evolve for a very long time so the observables of the system become time independent. For ergodic system, the ergodic theorem holds and the time average of observables can be replaced by averages over ensemble. The ensemble is characterized by the density matrix  $\rho$  which is the function of conserved charges  $Q_i$ . Generically, one system reaches the thermal equilibrium when it coupled to a external heat bath with certain properties. However, the recent experiments of cold atoms motivated studies of the close quantum systems not coupled to any reservoir [43, 44]. The time evolution of these systems under the time independent Hamiltonian  $H$  is clearly unitary so the system as a whole can never thermalize. This is because the process of thermalization is strictly related to the “erasure” of the system’s memory of all quantum information about the initial state. However, the unitary time evolution prevents the erasure process of quantum informations in the closed systems. The solution to this problem may be obtained by considering the expectation values

$$\langle\psi(t)|\mathcal{O}(t)|\psi(t)\rangle, \tag{A.1}$$

of local observable  $\mathcal{O}$  which acts on the subsystem of a large close quantum system instead of measuring global operators. The time-dependent state is given by

$$|\psi(t)\rangle = e^{-Ht} |\psi_0\rangle. \tag{A.2}$$

The expectation value in (A.1), taking the limit  $t \rightarrow \infty$ , will be equilibrated with respect to a appropriate statistical ensemble. This is because at large times, spreading of quantum entanglements, moves the information about the initial state. Hence, the

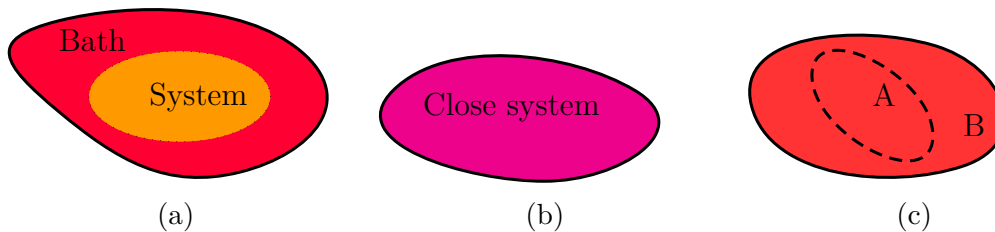

Figure A.1: In (a) it is represented the conventional quantum statistical scheme where the system under consideration is coupled to external bath. In picture (b), close quantum system with unitary time evolution. In (c), the total close system is partitioned in a subsystem  $A$  and complement system  $B$ , here  $B$  can be interpreted like a thermal bath.

result, is that, locally the information about initial state is “hidden”. This process is named “decoherence”. So, in the close quantum systems thermalization means the thermalization of some subsystem respect the rest of the total system which act as the heat bath.

Consider now an initial state  $|\psi(t_0)\rangle$ ,  $t_0 = 0$  expressed in terms of the eigenstates of the Hamiltonian,

$$|\psi(t)\rangle = \sum_{\nu} c_{\nu} e^{-iE_{\nu}t} |E_{\nu}\rangle \quad (\text{A.3})$$

where  $c_{\nu} = \langle E_{\nu} | \psi_0 \rangle$ . The mean value of some observable  $\mathcal{O}$  is given by

$$\begin{aligned} \langle \mathcal{O}(t) \rangle &= \sum_{\nu, \nu'} c_{\nu'}^* c_{\nu} e^{-i(E_{\nu} - E_{\nu'})t} \langle E_{\nu'} | \mathcal{O} | E_{\nu} \rangle \\ &= \sum_{\nu} |c_{\nu}|^2 \langle E_{\nu} | \mathcal{O} | E_{\nu} \rangle + \sum_{\nu \neq \nu'} c_{\nu'}^* c_{\nu} e^{-i(E_{\nu} - E_{\nu'})t} \langle E_{\nu'} | \mathcal{O} | E_{\nu} \rangle. \end{aligned} \quad (\text{A.4})$$

After a thermalization time  $t_{th}$ , the expectation value  $\langle \mathcal{O} \rangle_{th}$  should reach the time averaged value

$$\langle \mathcal{O} \rangle_{th} = \lim_{T \rightarrow \infty} \frac{1}{T} \int dt \langle \mathcal{O}(t) \rangle = \sum_{\nu} |c_{\nu}|^2 \langle E_{\nu} | \mathcal{O} | E_{\nu} \rangle. \quad (\text{A.5})$$

The second term in the second line of (A.4), after the thermalization time  $t_{th}$  should reduce to a constant such that the observable become time-independent. This mean that after the thermalization the off-diagonal elements  $\langle E_{\nu'} | \mathcal{O} | E_{\nu} \rangle$  should be small. However, in the last term of the previous equation the expansion term coefficient  $c_{\nu}$  depends on initial state  $\psi_0$  that seems to be in contradiction with the definition of thermal state. So, for a closed quantum system the requirement to be thermal is:

$$\sum_{\nu} |c_{\nu}|^2 \langle E_{\nu} | \mathcal{O} | E_{\nu} \rangle \simeq \langle \mathcal{O} \rangle_{m.c.} (E) \quad (\text{A.6})$$

and we also need the fluctuations to be small. This requirement is called “Eigenstate Thermalization Hypothesis” (ETH). So, this hypothesis states that the off-diagonal elements of local operators are exponentially small and the diagonal elements vary very smoothly with the energy.

## APPENDIX B

---

### Euler equations calculations

---

Here we will compute the equations (5.20) starting from (5.19). First we compute the derivatives

$$\begin{aligned} n(\theta)[\partial_t(p')^{dr}(\theta) + \partial_x(E')^{dr}(\theta)] + (p')^{dr}(\theta)\partial_t n(\theta) + (E')^{dr}(\theta)\partial_x n(\theta) &= 0, \\ n_1(\theta)[\partial_t(p_1')^{dr}(\theta) + \partial_x(E_1')^{dr}(\theta)] + (p_1')^{dr}(\theta)\partial_t n_1(\theta) + (E_1')^{dr}(\theta)\partial_x n_1(\theta) &= 0. \end{aligned} \quad (\text{B.1})$$

The derivation of the dressed quantities yields to

$$\begin{aligned} n(\theta)\{-\varphi * [\partial_t n_1(p_1')^{dr} + \partial_x n_1(E_1')^{dr}]\}(\theta) + (p')^{dr}(\theta)\partial_t n(\theta) + (E')^{dr}(\theta)\partial_x n(\theta) &= 0, \\ n_1(\theta)\{-\varphi * [\partial_t n(p')^{dr} + \partial_x n(E')^{dr}]\}(\theta) + (p_1')^{dr}(\theta)\partial_t n_1(\theta) + (E_1')^{dr}(\theta)\partial_x n_1(\theta) &= 0. \end{aligned} \quad (\text{B.2})$$

Due to the equations (5.19) the part inside square brackets vanishes. Now, if we divide the first equation of (B.2) by  $(p')^{dr}(\theta)$  and the second by  $(p_1')^{dr}(\theta)$  we obtain equations (5.19).

Now we compute the density of charges. From the equations (5.7) we have

$$\begin{aligned} (p')^{dr}(\theta) &= p'(\theta) + \varphi * n_1[\varphi * n(p')^{dr}](\theta), \\ (h_i)^{dr}(\theta) &= h_i(\theta) - \varphi * n_1[\varphi * n(h_i)^{dr}](\theta). \end{aligned} \quad (\text{B.3})$$



The density of charges are

$$\begin{aligned}
\underline{q}_i(\theta) &= \int d\theta [n(\theta)(p')^{dr}(\theta)h_i(\theta)] = \\
&\int d\theta \{n(\theta)(p')^{dr}(\theta)h_i(\theta) - h_i(\theta)(p')^{dr}(\theta)[\varphi * n_1(\varphi * n(h_i)^{dr})](\theta)\} = \\
&\int d\theta [n(\theta)(p')^{dr}(\theta)h_i(\theta)] - \tag{B.4} \\
&\iiint d\theta d\theta' d\gamma \{n(\theta)(h_i)^{dr}(\theta)\varphi(\theta - \theta')n_1(\theta')\varphi(\theta' - \gamma)n(\gamma)(p')^{dr}(\gamma) - \\
&n(\theta)(p')^{dr}(\theta)\varphi(\theta - \theta')n_1(\theta')\varphi(\theta' - \gamma)n(\gamma)(h_i)^{dr}(\gamma)\}.
\end{aligned}$$

If we change the variables  $\theta \rightarrow \gamma$ ,  $\gamma \rightarrow \theta$ , in the last line, the triple integral vanish.

## APPENDIX C

---

### Lie algebras

---

In this brief review we will consider simple (finite-dimensional) Lie algebra. A Lie algebra  $g$  of dimension  $n$  is defined as a vector space with an operation  $[\cdot, \cdot] : g \times g \rightarrow g$  such that the Jacobi identity

$$[x, [y, z]] + [z, [x, y]] + [y, [z, x]] = 0 \quad x, y, z \in g \quad (\text{C.1})$$

is satisfied. A Lie algebra  $g$  can be connected to the correspondent Lie group  $G$  through the exponential map, namely to an element  $x \in g$  has its correspondent element  $e^{iax}$ , where  $a$  is some parameter.

A Lie algebra can be defined from the generators  $\lambda_i$ , where  $i = 1, \dots, n$  ( $n$  dimension of Lie algebra). The generators satisfy

$$[\lambda_i, \lambda_j] = \sum_k i f_{ij}^k \lambda_k, \quad (\text{C.2})$$

where  $f_{ij}^k$  are structure constants.

In the theory of Lie algebras a very important concept is that of the representations of Lie algebras. They are defined by associating each element of the algebra to a linear operator (or square matrix), which satisfy the Jacobi identity. A particular representation is *adjoint representation* where the generators act on their Lie algebra. Formally, all elements of group  $g$  are associated with a linear application  $ad(x) : g \rightarrow g$ ,  $x \in g$  and

$$ad(x)y = [x, y]. \quad (\text{C.3})$$

The adjoint representation can be also specified using the structure constants by defining  $a_{jk}^i = -if_{ij}^k$ .

The set of structure constants of the adjoint representation  $a_{jk}^i$  contains a set of commuting matrices  $h^i$  where  $i = 1, \dots, r$  with  $r$  rank of the algebra. These matrices form the *Cartan sub-algebra*

$$[h^i, h^j] = 0, \quad h^i = h^{i\dagger}. \quad (\text{C.4})$$

The remaining set of  $(n - r)$  matrices will be denoted with  $e^i$  and they are defined as follows

$$[h^i, e^{\alpha^j}] = (\alpha^j)_i e^{\alpha^j}. \quad (\text{C.5})$$

Where  $(\alpha^j)_i$  is known as *root*. All roots define a matrix  $d - r \times r$ , each row defines a root vector  $\alpha = (\alpha^1, \dots, \alpha^r)$ . From now, with root we will refer to root vector (we will omit component's index). For all roots holds the property that if  $\alpha$  is a root  $c\alpha$  is also a root for  $c = -1, 0$ .

The set of all roots generally are linearly dependent. A convenient base of  $r$  linearly independent roots can be defined by using  $r$  *simple roots*. A root is called *positive* if the first element of the vector is positive. *Simple roots* are positive roots and they cannot be expressed as a sum of two positive roots. All roots can be expanded as

$$\beta = \sum_{i=1}^r n_i \alpha_i \quad (\text{C.6})$$

where  $\alpha_i$  are simple roots. The highest root is a root for which the sum  $\sum_{i=1}^r n_i$  is maximized.

We define the scalar product between roots

$$\langle \alpha | \beta \rangle = \sum_i \alpha^i \beta^i. \quad (\text{C.7})$$

The *Cartan matrix* is given by

$$C_{ij} = \frac{\langle \alpha_i | \alpha_j \rangle}{\langle \alpha_j | \alpha_j \rangle}. \quad (\text{C.8})$$

The entries of the Cartan matrix are integers and the elements on the diagonal are equal to 2.

We define *coroots*  $\alpha_i^\vee$  associated to roots  $\alpha_i$ , as

$$\alpha_i^\vee = \frac{2\alpha_i}{|\alpha_i|^2}, \quad |\alpha_i|^2 = \langle \alpha_i | \alpha_i \rangle. \quad (\text{C.9})$$

and the *dual Coxeter number* is given by

$$g = \sum_{i=1}^r \alpha_i^\vee + 1. \quad (\text{C.10})$$

The study of Cartan matrix and its constraints on the simple roots leads to the classification of the simple Lie algebras which are given in (Table C.1). Different algebras can be graphically represented by the *Dynkin diagrams* where to each node is attached a simple root. Dynkin diagrams are associated to the Cartan matrices. For example, the Cartan matrix of the  $A_r$  algebra is  $r \times r$  matrix

$$C_{ij}^{(r)} = \begin{pmatrix} 2 & -1 & 0 & \dots & 0 \\ -1 & 2 & -1 & & \vdots \\ 0 & -1 & 2 & & 0 \\ \vdots & & & \ddots & -1 \\ 0 & \dots & 0 & -1 & 2 \end{pmatrix}. \quad (\text{C.11})$$

Algebra	Dynkin diagram	Dimension	dual Coxeter number	Group
$A_r$		$r^2 + 2r$	$r + 1$	$SU(r + 1)$
$B_r$		$2r^2 + r$	$2r - 1$	$O(2r + 1)$
$C_r$		$2r^2 + r$	$r + 1$	$Sp(2r)$
$D_r$		$2r^2 - r$	$2r - 2$	$O(2r)$
$G_2$		14	4	
$F_4$		52	9	
$E_6$		78	12	
$E_7$		133	18	
$E_8$		248	30	

Table C.1: The classification of simple Lie algebras.

---

## Bibliography

---

- [1] J.-P. Brantut et al., A thermoelectric heat engine with ultracold atoms, *Science Reports* **342**, 713 (2013)
- [2] S. Jezouin et al, Quantum limit of heat flow across a single electronic channel, *Science* **342**, 601 (2013).
- [3] D. Bernard and B. Doyon, Conformal field theory out of equilibrium: a review, arXiv:1603.07765.
- [4] O. Castro-Alvaredo, Y. Chen, B. Doyon, and M. Hoogeveen, Thermodynamic Bethe ansatz for non-equilibrium steady states: exact energy current and fluctuations in integrable QFT, *J. Stat. Mech.* (2014) P03011.
- [5] O. A. Castro-Alvaredo, B. Doyon, and T. Yoshimura, Emergent hydrodynamics in integrable systems out of equilibrium, *Phys. Rev. X* **6**, 041065 (2016).
- [6] B. Bertini, M. Collura, J. De Nardis, and M. Fagotti, Transport in Out-of-Equilibrium XXZ Chains: Exact Profiles of Charges and Currents, *Phys. Rev. Lett.* **117**, 207201 (2016).
- [7] B. Doyon and T. Yoshimura, A note on generalized hydrodynamics: inhomogeneous fields and other concepts, arXiv:1611.08225.
- [8] B. Doyon, J. Dubail, R. Konik, and T. Yoshimura, Generalized hydrodynamics and density waves in interacting one-dimensional Bose gases, arXiv:1704.04151.
- [9] B. Doyon, H. Spohn, and T. Yoshimura, A geometric viewpoint on generalized hydrodynamics, arXiv:1704.04409.

- [10] B. Doyon, T. Yoshimura, and J.-S. Caux, Soliton gases and generalized hydrodynamics, arXiv:1704.05482.
- [11] V. B. Bulchandani, R. Vasseur, C. Karrasch, J. E. Moore, Bethe-Boltzmann Hydrodynamics and Spin Transport in the XXZ Chain arXiv:1702.06146.
- [12] V. B. Bulchandani, R. Vasseur, C. Karrasch, J. E. Moore, Solvable Hydrodynamics of Quantum Integrable Systems, arXiv:1704.03466.
- [13] T. Palmai, R. M. Konik, Quasi-local charges and the Generalized Gibbs Ensemble in the Lieb-Liniger model, arXiv:1710.11289v2.
- [14] E. Ilievski, J. D. Nardis, B. Wouters, J. Caux, F. H. L. Essler, T. Prosen, Complete Generalized Gibbs Ensemble in an interacting Theory, arXiv:1507.02993.
- [15] B. Doyon, Thermalization and pseudolocality in extended quantum systems, arXiv:1512.03713v3.
- [16] E. Ilievski, M. Medenjak, T. Prosen, L. Zadnik, arXiv:1603.00440.
- [17] T. Kinoshita, T. Wenger, and D. S. Weiss, A Quantum Newtons Cradle, Nature 440, 900-903 (2006).
- [18] J. S. Caux, B. Doyon, J. Dubail, R. Konik, T. Yoshimura, Hydrodynamics of the interacting Bose gas in the Quantum Newton Cradle setup, arXiv:1711.00873v2.
- [19] D. Bombardelli, Lectures on S-matrices and Integrability, arXiv:1606.02949.
- [20] O. A. Castro-Alvared, Bootstrap Methods in 1+1-Dimensional Quantum Field Theories: the Homogeneous Sine-Gordon Models, arXiv:0109212v1.
- [21] P. Dorey, Exact S-matrices, arXiv:9810026v1.
- [22] G. Mussardo, Statistical Field Theory: An Introduction to Exactly Solved Models in Statistical Physics, Oxford University Press.
- [23] S. J. Parke, Absence of Particle Production and Factorization of the S Matrix in (1+1)-dimensional Models, Nucl. Phys. B 174 (1980) 166.
- [24] A.B. Zamolodchikov, Integrable field theory from conformal field theory, Adv. Stud. Pure Math., 19 (1989), 641.
- [25] A. B. Zamolodchikov, Thermodynamic Bethe Ansatz in Relativistic Models. Scaling Three State Potts and Lee-Yang Models, Nucl. Phys. B342 (1990) 695720.

- [26] T.R. Klassen and E. Melzer, The thermodynamics of purely elastic scattering theories and conformal perturbation theory, Nucl . Phys. B350 (1991) 635.
- [27] T.R. Klassen and E. Melzer, Purely elastic scattering theories and their ultraviolet limits, Nucl . Phys. B338 (1990) 485-528.
- [28] AI. B. Zamolodchikov, On the thermodynamic Bethe ansatz equations for reflection-less ADE scattering theories, Phys. Letter B, Volume 253, number 3,4, 10 January 1991.
- [29] F. Ravanini, R. Tateo, A. Valleriani, DYNKIN TBAS, arXiv:9207040v1.
- [30] J. Mossel, J. S. Caux, Generalized TBA and generalized Gibbs J. Phys. A:Math. Theor. 45 (2012) 255001 (10pp).
- [31] L. D. Faddeev, How algebraic Bethe ansatz works for integrable models, hep-th/9605187.
- [32] T. J. Hollowood, From  $A_{m-1}$  trigonometric S-matrices to the thermodynamic Bethe Ansatz, Phys. Letter B, Volume 320, (1994) 43-51.
- [33] A. Babichenko, From S-matrices to the Thermodynamic Bethe Ansatz, arXiv:0402164v2.
- [34] AI.B. Zamolodchikov, TBA EQUATIONS FOR INTEGRABLE PERTURBED  $SU(2)_k \times SU(2)_l / SU(2)_{k+l}$  COSET MODELS, Nuclear Physics B366 (1991) 122-132.
- [35] T. J. Hollowood, THE ANALYTIC STRUCTURE OF TRIGONOMETRIC S MATRICES, arXiv:hep-th/9305042.
- [36] A. Kuniba, Thermodynamics of the  $U_q(X_r^{(1)})$  Bethe ansatz system with  $q$  a root of unity, Nuclear Physics B389 (1993) 209244.
- [37] V. V. Bazhanov, N. Reshetikhin, Restricted solid-on-solid models connected with simply laced algebras and conformal field theory, 1990 J. Phys. A: Math. Gen. 23 1477.
- [38] D. Bernard and B. Doyon, Energy flow in non-equilibrium conformal field theory, J. Phys. A: Math. Theor. 45 (2012), 362001.
- [39] M. LASSIG, G. MUSSARDO, J. L. CARDY, The scaling region of the tricritical Ising model in two dimensions, Nuclear Physics B348(1991)591-618.
- [40] P. Di Francesco, P. Mathieu, D. Senechal, Conformal field theory, Springer, 1997.

- [41] E. Vernier, A. C. Cubero, Quasilocal charges and progress towards the complete GGE for field theories with non-diagonal scattering, arXiv:1609.03220v3.
- [42] Diffusion in generalized hydrodynamics and quasiparticle scattering, J. D. Nardis, D. Bernard, B. Doyon, arXiv:1812.00767.
- [43] R. Nandkishore, D. A. Huse, Many-body localization and thermalization in quantum statistical mechanics, arXiv:1404.0686v2.
- [44] S. Khlebnikov, M. Kruczenski, Thermalization of isolated quantum systems, arXiv:1312.4612v2.